

IDP-5000-04A Touch Display Module Datasheet



1 Introduction

The IDP-5000-04A is a smart display module featuring a 5" TFT LCD panel with an 800x480 resolution and 16.7M colours with capacitive touch interface. It incorporates Bridgetek's proprietary Embedded Video Engine (EVE) Graphics Controller, the FT813, to deliver rich, interactive, multi-touch user experiences. The module is powered by Bridgetek's FT903 System-On-Chip microcontroller, known for its high integration and low power consumption.

Designed for intuitive control and monitoring, the IDP-5000-04A Touch Display enables users to trigger events effortlessly. Unlike mobile devices that require frequent recharging, it can be installed in accessible locations and continuously powered via a Cat 5e cable.

1.1 Features

- Integrated FT903 32-bit RISC microcontroller with 100MHz system clock
- Built-in advanced FT813 graphics controller with display, touch, and audio functionality
- 5-inch high-brightness 800x480 resolution TFT LCD with support for capacitive 5-point touch
- Ambient light sensor for adaptive brightness control
- Integrated buzzer for audio notifications
- Two RJ45 Ports supporting RS485 Interface for data communication, allowing daisy chain to another IDP-5000-04A module
- Powered by a 9V-24V DC supply through an RJ45 port

Neither the whole nor any part of the information contained in, or the product described in this manual, may be adapted, or reproduced in any material or electronic form without the prior written consent of the copyright holder. This product and its documentation are supplied on an as-is basis and no warranty as to their suitability for any particular purpose is either made or implied. Bridgetek Pte Ltd will not accept any claim for damages howsoever arising as a result of use or failure of this product. Your statutory rights are not affected. This product or any variant of it is not intended for use in any medical appliance, device, or system in which the failure of the product might reasonably be expected to result in personal injury. This document provides preliminary information that may be subject to change without notice. No freedom to use patents or other intellectual property rights is implied by the publication of this document. Bridgetek Pte Ltd, 1 Tai Seng Avenue, Tower A, #03-05, Singapore 536464. Singapore Registered Company Number: 201542387H.

1.2 Typical Applications

- Home Automation Systems: Smart Thermostats, Lighting Control.
- Audio Equipment: Mixing Consoles, Hi-Fi Systems.
- Medical Devices: Portable Medical Monitors, Patient Monitoring Devices.
- Industrial Applications: Control Panels, Measurement Instrument.
- Automotive Interfaces: Infotainment Systems, Dashboards
- Consumer Electronics: Smart Speakers and Media Players, portable Gaming Consoles.
- Test and Measurement Equipment such as Oscilloscopes and Multi-meters.
- and many more.

2 Part Number/Ordering Information/Package Content

Part No.	Description
IDP-5000-04A	Intelligent Display Product 5 inch with Enclosure

Table 1 - Part Number/Ordering Information

Description	
Hardware	IDP-5000-04A Display Module
components	M3 Screws (Arlington LV2 Wall Mounting) x4

Table 2 - Package Content

Table of Contents

1	Introduction	1
1.1	Features.....	1
1.2	Typical Applications	2
2	Part Number/Ordering Information/Package Content	3
3	Hardware Features.....	6
3.1	Module Overview	6
3.2	PCBA Profile.....	7
3.2.1	Mainboard	7
3.2.2	Sensor board	8
3.2.3	Key Features.....	8
3.3	PCB Profile	8
3.4	Connectors, Switches and Buttons	10
4	Board Schematics.....	14
5	Device Description and Configuration	18
5.1	Power Supply	19
5.2	Microcontroller.....	19
5.3	Graphic Controller.....	19
5.4	RJ45 Ports	19
5.4.1	Pin Definition	19
5.4.2	Powering and Communication	20
5.4.3	Port Connection.....	21
5.4.4	Port termination	21
5.5	LED Indicator	22
5.6	ID Switch	22
5.7	Reset Button	22
5.8	Micro USB	22
5.9	One Wire Debug	22
5.10	Buzzer.....	22
5.11	Microphone	22
6	Specifications.....	23

6.1	Electrical Specifications	23
6.2	Optical Specifications.....	24
7	Mechanical Dimensions and Mounting Guides	25
7.1	Dimensions	25
7.2	Mounting Guides	26
8	Software Setup Information.....	27
8.1	Startup Test	27
8.2	Firmware Download and Debugging Methods for FT903 MCU .	28
8.3	Software Development Tools and Support	29
9	Disclaimer Notice: Use of Third-Party Software or Websites	30
10	Warranty Statement.....	31
11	Contact Information.....	32
	Appendix A - References	33
	Document References	33
	Acronyms and Abbreviations	33
	Appendix B - List of Figures and Tables	34
	List of Figures	34
	List of Tables	34
	Appendix C – Revision History	36

3 Hardware Features

3.1 Module Overview

The IDP-5000-04A module features a 5-inch TFT LCD and CTP panel with dimensions of 145.09 mm (L) X 116.37 (W) X 16.72mm (T) and weighing 275g.



Figure 1 - Front View of IDP-5000-04A Module



Figure 2 - Back View of IDP-5000-04A Module

3.2 PCBA Profile

The IDP-5000-04A display module is made up of two boards:

1. **Mainboard:** PCBA containing microprocessor and graphics controller ICs.
2. **Sensor Board:** PCBA containing reset button, microphone, ambient light sensor and smart RGB LED.

3.2.1 Mainboard

Dimensions of main board: 131mm (L) X 86.5mm (W) X 1.6mm (T) with maximum component height of approximately 13mm.

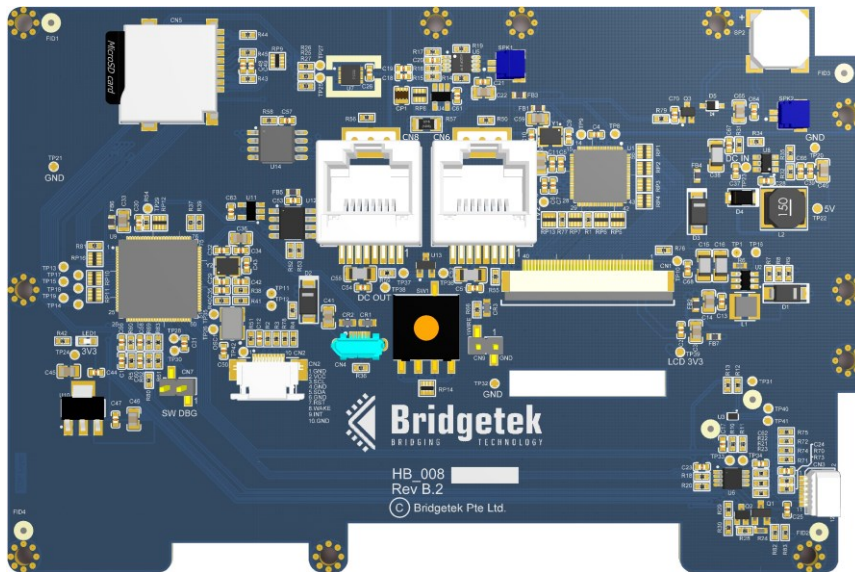

Figure 3 - Mainboard PCBA Front View

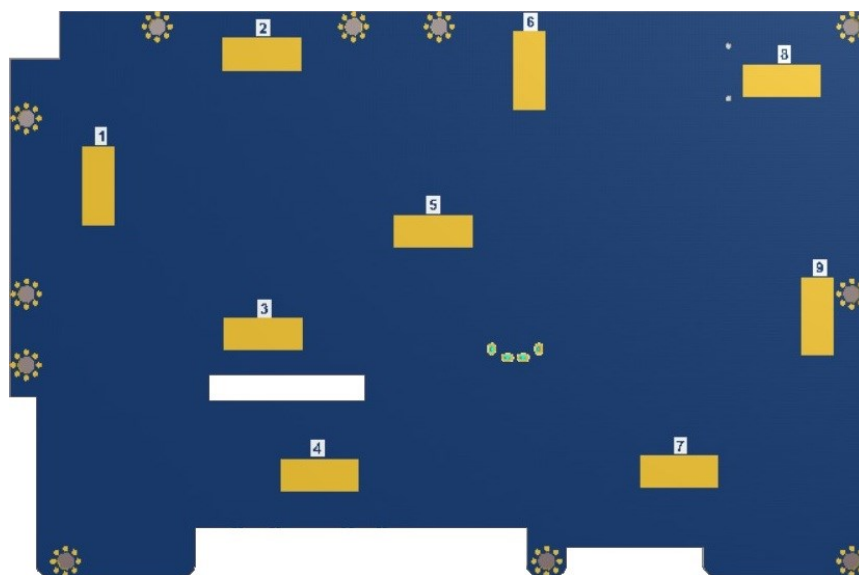

Figure 4 - Mainboard PCBA Back View

3.2.2 Sensor board

Dimensions of sensor board: 29.5mm (L) X 6.5mm (W) X 1.6mm (T) with maximum component height of approximately 3.6mm (H).

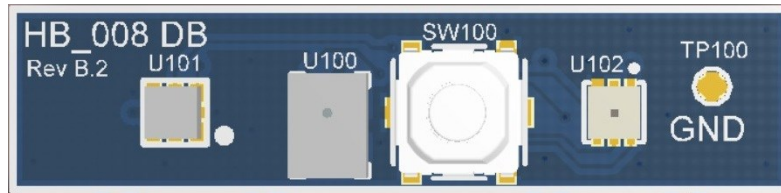

Figure 5 - Sensor Board Front View

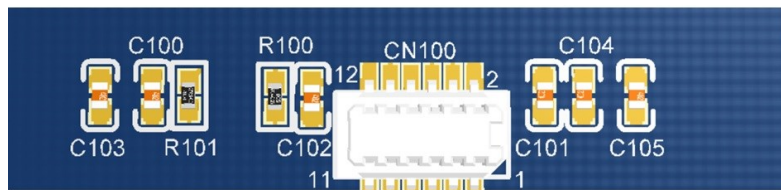

Figure 6 - Sensor Board Back View

3.2.3 Key Features

- ❖ 5-inch 800 x 480 TFT-LCD panel with capacitive touch panel
- ❖ Bridgetek FT813 EVE chip for graphics, touch, and audio control
- ❖ LED backlight driver integrated
- ❖ Bridgetek FT903 microcontroller
- ❖ 8Mbyte NOR Flash for FT903 data storage
- ❖ Micro-SD card socket
- ❖ Micro USB port for communication to FT903 MCU
- ❖ Two RJ45 ports for I/O supply and RS485 communication
- ❖ Built-in audio buzzer for sound notifications
- ❖ Built-in digital microphone
- ❖ Built-in ambient light sensor
- ❖ Built-in smart LED indicator
- ❖ ID switch for unique ID setting
- ❖ Hardware reset button

3.3 PCB Profile

Both printed circuit boards (PCBs) in the IDP-5000-04A module are designed with four layers, stacked as follows:

1. Layer 1: Routing & Component placement (Top)
2. Layer 2: Ground Plane
3. Layer 3: Power Plane
4. Layer 4: Routing & Component placement (Bottom)

Figure 7 to Figure 10 illustrate the layout of these PCBs.

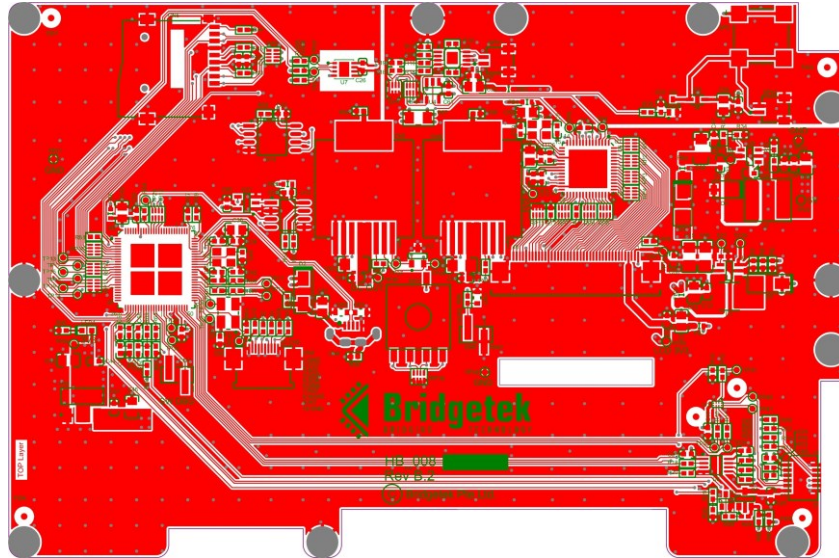
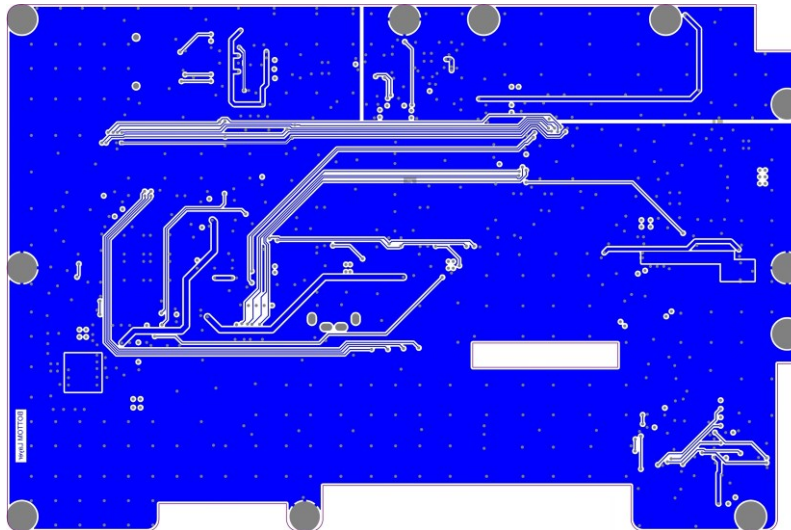
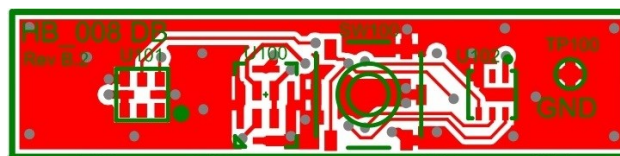
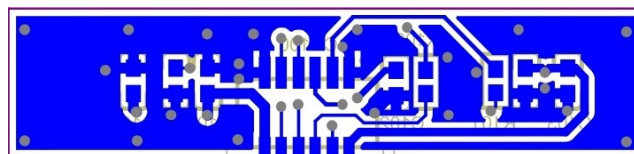
**Figure 7 - Main PCB Top Layer****Figure 8 - Main PCB Bottom Layer****Figure 9 - Sensor PCB Top Layer****Figure 10 - Sensor PCB Bottom Layer**

3.4 Connectors, Switches and Buttons

The following section provides details about the connectors, their pin configurations and the functions of the switches and buttons on the boards. Refer to Figure 3 for connector locations.

- **CN1 – LCD Panel Interface**

This 40-position, 0.5mm pitch top-contact FPC connector is used for inter-connection to the 5-inch LCD panel. The manufacturer's part number for this connector is "62684-402100ALF."

Pin No.	Name	Type	Description
1	LEDK	P	LED Cathode
2	LEDA	P	LED Anode
3	GND	P	Ground
4	VDD_3V3	P	3.3V Output power supply
5	LCD R0	O	Red channel intensity bit 0
6	LCD R1	O	Red channel intensity bit 1
7	LCD R2	O	Red channel intensity bit 2
8	LCD R3	O	Red channel intensity bit 3
9	LCD R4	O	Red channel intensity bit 4
10	LCD R5	O	Red channel intensity bit 5
11	LCD R6	O	Red channel intensity bit 6
12	LCD R7	O	Red channel intensity bit 7
13	LCD G0	O	Green channel intensity bit 0
14	LCD G1	O	Green channel intensity bit 1
15	LCD G2	O	Green channel intensity bit 2
16	LCD G3	O	Green channel intensity bit 3
17	LCD G4	O	Green channel intensity bit 4
18	LCD G5	O	Green channel intensity bit 5
19	LCD G6	O	Green channel intensity bit 6
20	LCD G7	O	Green channel intensity bit 7
21	LCD B0	O	Blue channel intensity bit 0
22	LCD B1	O	Blue channel intensity bit 1
23	LCD B2	O	Blue channel intensity bit 2
24	LCD B3	O	Blue channel intensity bit 3
25	LCD B4	O	Blue channel intensity bit 4
26	LCD B5	O	Blue channel intensity bit 5
27	LCD B6	O	Blue channel intensity bit 6
28	LCD B7	O	Blue channel intensity bit 7
29	GND	P	Ground
30	LCD PCLK	O	Pixel clock line to LCD
31	LCD DISP	O	Enable Display to LCD
32	LCD HC	O	Horizontal sync signal line to LCD
33	LCD VC	O	Vertical sync signal line to LCD
34	LCD DE	O	Enable valid pixel data being sent to LCD
35	GND	P	Ground

36	GND	P	Ground
37	-	-	Reserved. Do not connect
38	-	-	Reserved. Do not connect
39	-	-	Reserved. Do not connect
40	-	-	Reserved. Do not connect

Table 3 - CN1 Pinout

- **CN2 – Capacitive Touch Panel Interface**

The 10-position 0.5mm pitch top-contact FFC connector provides support to LCD panels with capacitive touch function.

Pin No.	Name	Type	Description
1	GND	P	Ground
2	VCC	P	Output power supply
3	SCL	O	I2C serial bus, clock line
4	GND	P	Ground
5	SDA	I/O	I2C serial bus, data line
6	GND	P	Ground
7	RST#	O	Reset output to CTP
8	WAKE	NA	No Connection
9	INT#	I	Interrupt input from CTP
10	GND	P	Ground

Table 4 - CN2 Pinout

- **CN3 – Sensor board Inter-Connector**

The 12-position, 0.8mm pitch right-angle header serves as an interconnect for the sensor board.

Pin No.	Name	Type	Description
1	VDD_3V3	P	3.3V Output power supply
2	GND	P	Ground
3	AMLSCS	O	I2C serial bus, clock line
4	AMLINT	I	Interrupt input from ambient light sensor
5	RESET#	I	Reset input to MCU
6	AMLSDA	I/O	I2C serial bus, data line
7	PDM_DAT	I	Microphone data line
8	PDM_CLK	O	Microphone clock line
9	LED_K	O	Smart LED clock line
10	LED_D	O	Smart LED data line
11	LED_5V	P	5V Output power supply
12	GND	P	Ground

Table 5 - CN3 Pinout

- **CN4 – Micro-USB Receptacle**

The micro-USB receptacle enables PC communication with FT903 MCU and device firmware debug and updates.

- **CN5 - Micro SD Card Connector**

Supports SPI communication mode with auto card detection.

- **CN6 – RJ45 Interface In**

The 8-position, 1.5mm pitch right-angle RJ45 connector supports an RS485 interface for communication with external host devices and accepts a 24V power input from an external source.

Pin No.	Name	Type	Description
1	RS485_B/Z	I/O	Inverting receiver input and inverting driver output. Pin is an input if DE = 0; pin is an output if DE = 1
2	RS485_A/Y	I/O	Noninverting receiver input and noninverting driver output. Pin is an input if DE = 0; pin is an output if DE = 1.
3	NA	I	Pin shorted to 6
4	DC_IN	P	24V Input power supply
5	DC_IN	P	24V Input power supply
6	NA	I	Pin shorted to 3
7	GND	P	Ground
8	GND	P	Ground

Table 6 - CN6 Pinout

- **CN8 – RJ45 Connector Out**

The 8-position right-angle RJ45 connector supports an RS485 interface for communication and supplies power to connected external devices.

Pin No.	Name	Type	Description
1	RS485_B/Z	I/O	Inverting receiver input and inverting driver output. Pin is an input if DE = 0; pin is an output if DE = 1
2	RS485_A/Y	I/O	Noninverting receiver input and noninverting driver output. Pin is an input if DE = 0; pin is an output if DE = 1.
3	NA	I	Pin shorted to 6
4	DC_OUT	P	Output power supply from DC_IN
5	DC_OUT	P	Output power supply from DC_IN
6	NA	I	Pin shorted to 3
7	GND	P	Ground
8	GND	P	Ground

Table 7 - CN8 Pinout

- **CN9 – Debug Header**

The 2-postion 2.54mm pitch header is used for debugging the onboard FT903 microcontroller.

Pin No.	Name	Type	Description
1	GND	P	Ground
2	DBG	I/O	For in-circuit debugging

Table 8 - CN9 Pinout

- **CN100 – Mainboard Inter-Connector**

The 12-position, 0.8mm pitch right-angle receptacle serves as an interconnect to the mainboard.

Pin No.	Name	Type	Description
1	D3V3	P	3.3V input power supply
2	GND	P	Ground
3	AML_SCL	I	Ambient light sensor I2C clock line
4	AML_INT	O	Ambient light sensor interrupt output, open drain
5	RSTn	O	Reset output signal
6	AML_SDA	I/O	Ambient light sensor I2C data line
7	MIC_DAT	O	Microphone data output
8	MIC_CLK	I	Microphone clock line
9	LED_CLK_1	I	RGB LED clock line
10	LED_DAT_1	I	RGB LED data line
11	D5V	P	5V Output power supply
12	GND	P	Ground

Table 9 - CN100 Pinout

- **SW1** is a 4-position rotary switch used for configuring a unique ID for the device.
- **SW100** is hardware reset button to reset FT903 MCU.

4 Board Schematics

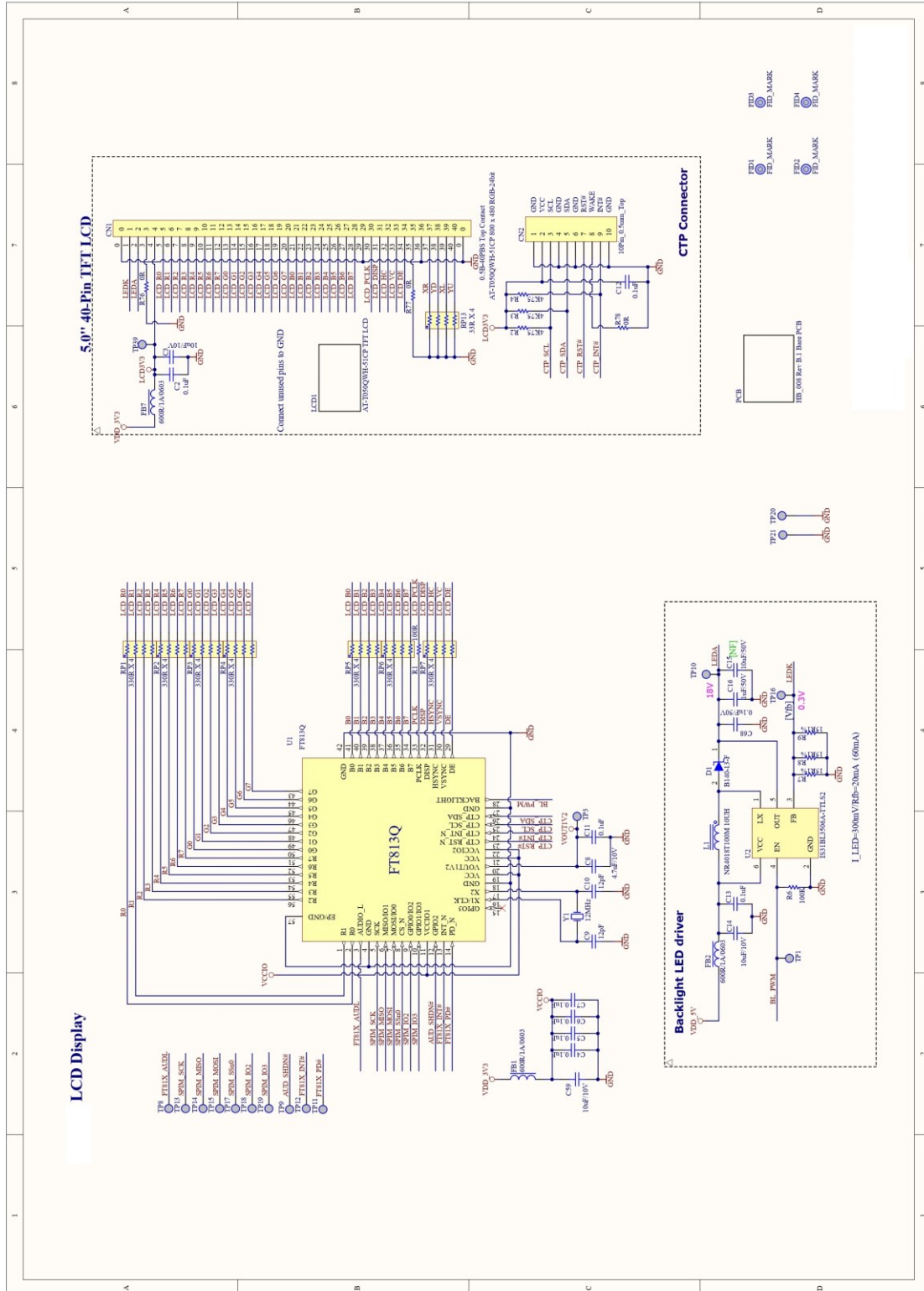

Figure 11 - 5-inch TFT LCD Display

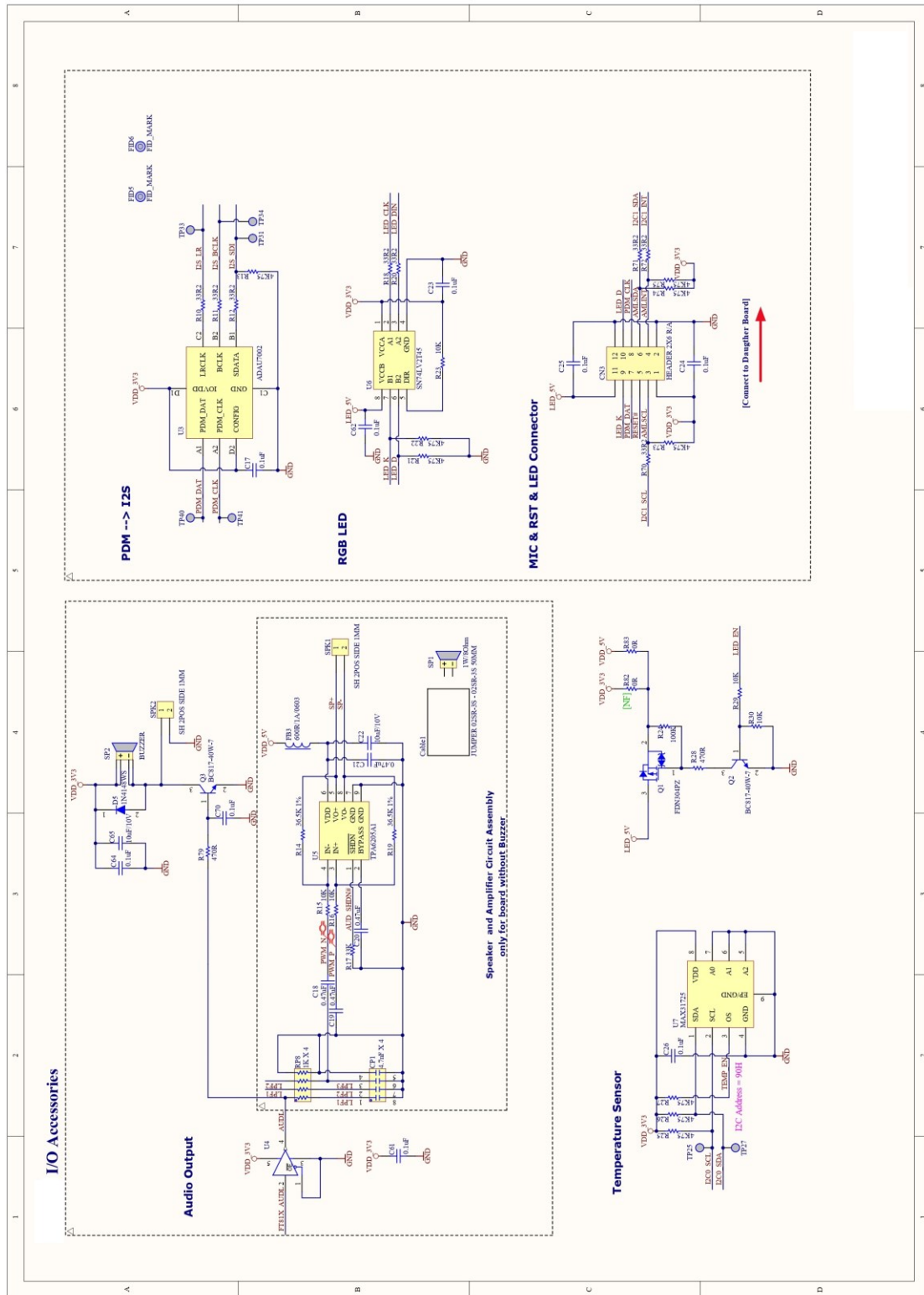

Figure 12 - I/O Accessories

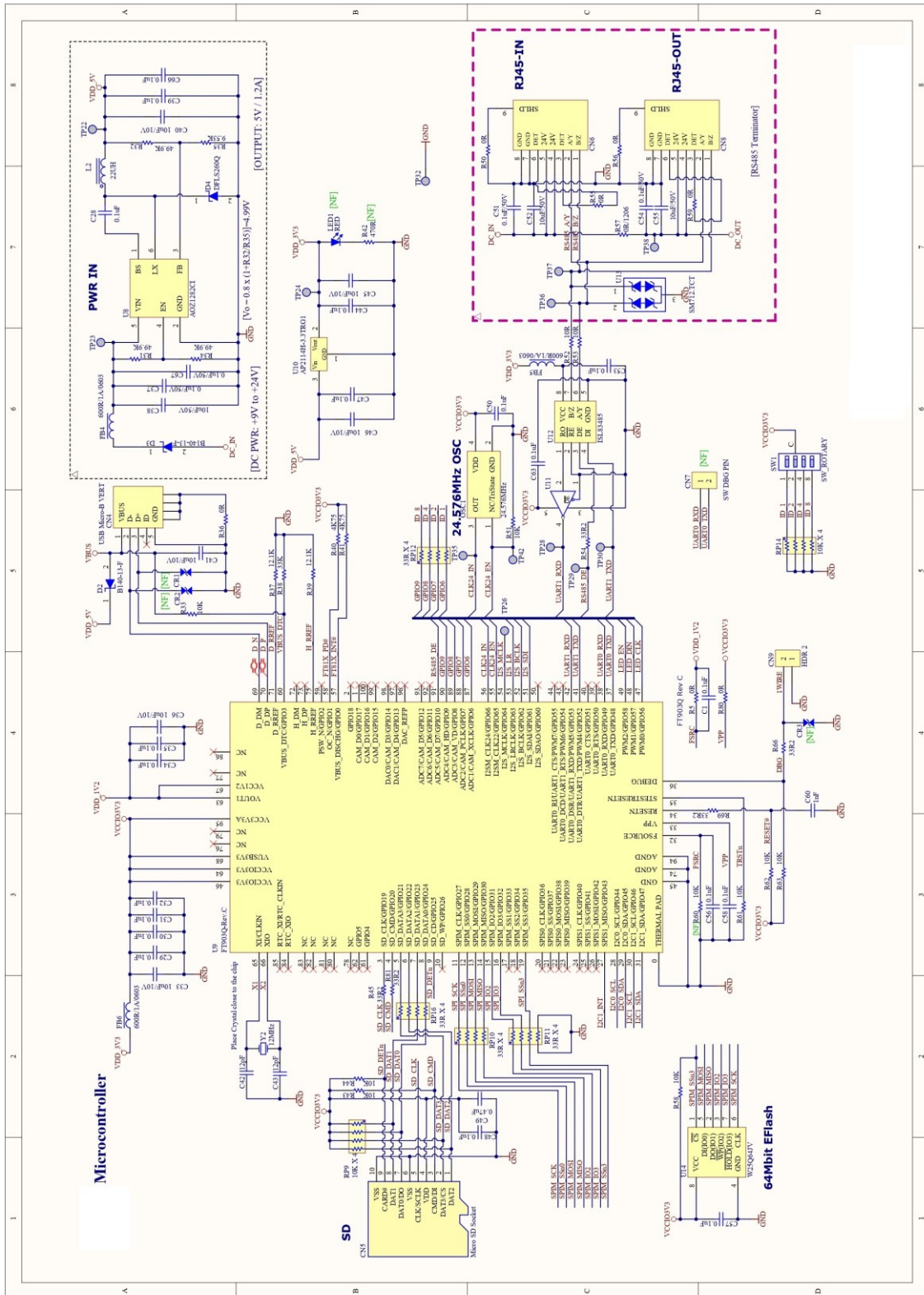

Figure 13 - MCU Controller

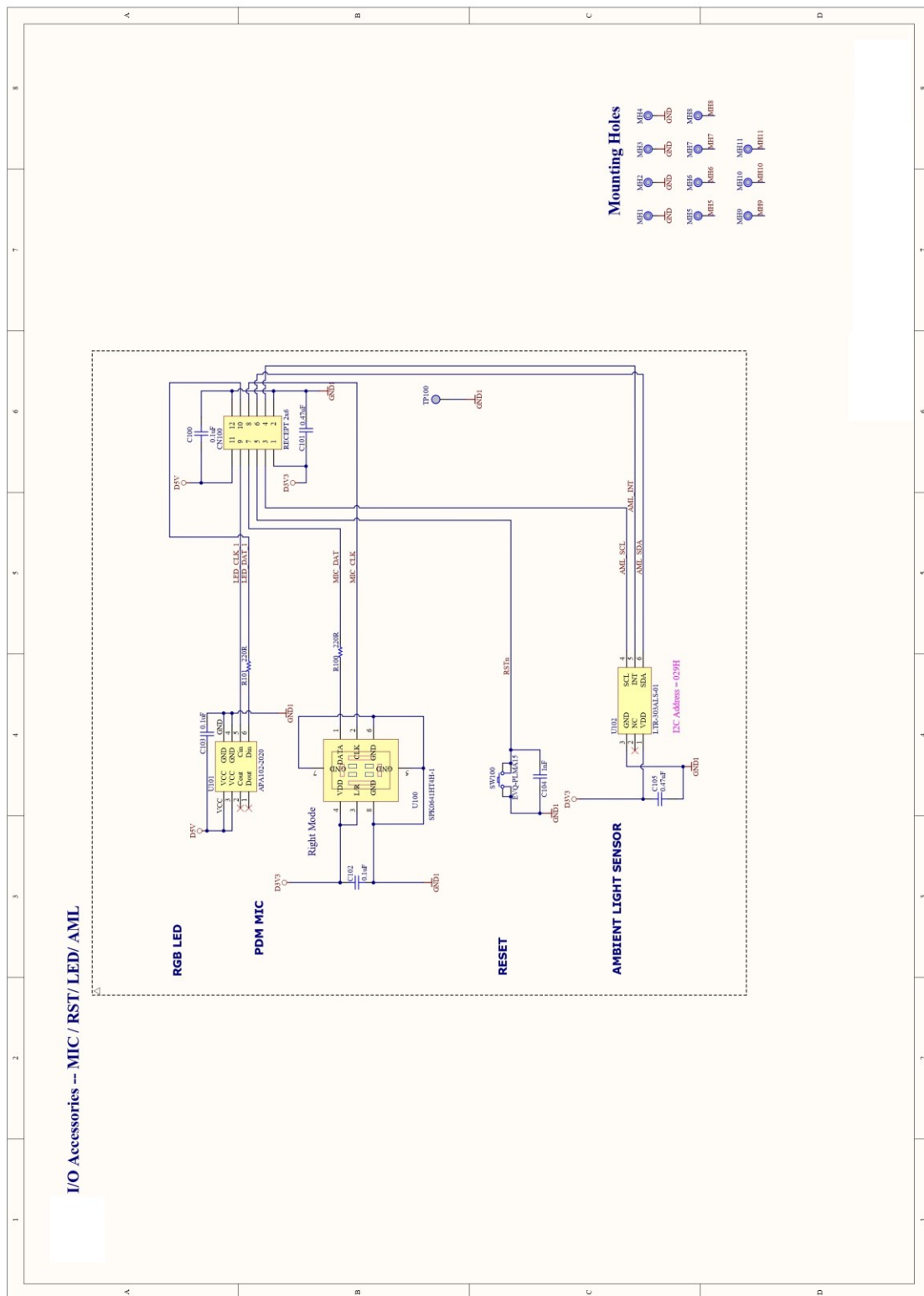

Figure 14 - Sensor Board

5 Device Description and Configuration

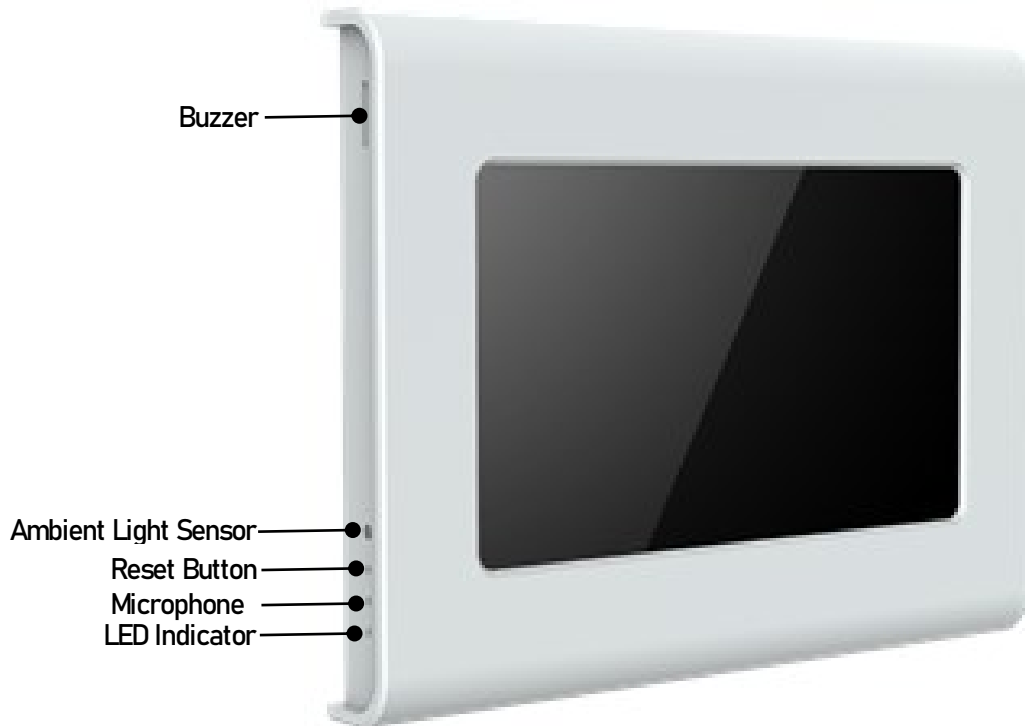

Figure 15 - IDP-5000-04A Touch Display Front View

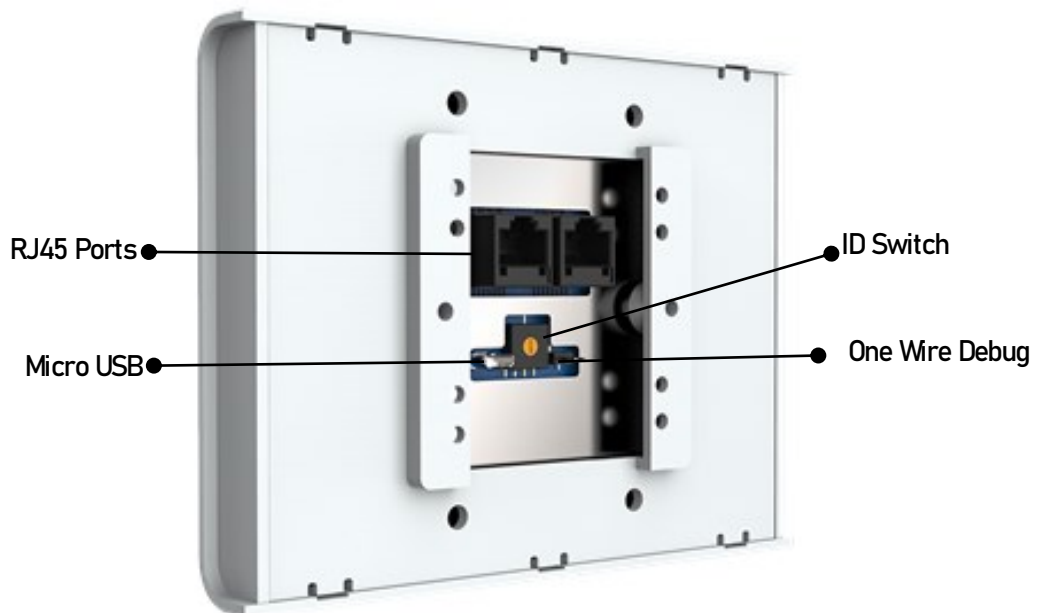

Figure 16 - IDP-5000-04A Touch Display Rear View

5.1 Power Supply

The IDP-5000-04A display module is powered through the RJ45 port on its back and can also output power directly from the input source. It supports an input voltage range of 9VDC to 24VDC, with a recommended power source of at least 6W.

5.2 Microcontroller

The display module is powered by the [FT903](#), a 32-bit RISC microcontroller from Bridgetek's System-On-Chip series, featuring:

- 32-bit FT32 core processor running at 100MHz
- 256kB on-chip flash memory
- 256kB on-chip shadow program memory
- 64kB of on-chip data memory
- OTP memory for security configuration
- USB 2.0 EHCI-compatible host controller supporting high-speed (480 Mbit/s), full-speed (12 Mbit/s), and low-speed (1.5 Mbit/s)
- USB 2.0 device controller supporting high-speed (480 Mbit/s) and full-speed (12 Mbit/s)

Bridgetek provides a free software toolchain to streamline the creation and downloading of .bin files. The [FT9xx-Toolchain](#) is available for download on the Bridgetek website.

5.3 Graphic Controller

The IDP-5000-04A utilizes Bridgetek's second-generation Advanced Embedded Video Engine (EVE) [FT813](#) for high-quality Human Machine Interfaces (HMIs), integrating graphic control, audio, and touch interface capabilities.

Bridgetek provides the [EVE Toolchains](#), an essential suite of tools for free, enabling developers to design impressive and highly responsive graphics user interfaces (GUIs) for EVE-based solutions. The toolchain contains the following tools:

- EVE Screen Designer
- EVE Screen Editor
- EVE Asset Builder

5.4 RJ45 Ports

5.4.1 Pin Definition

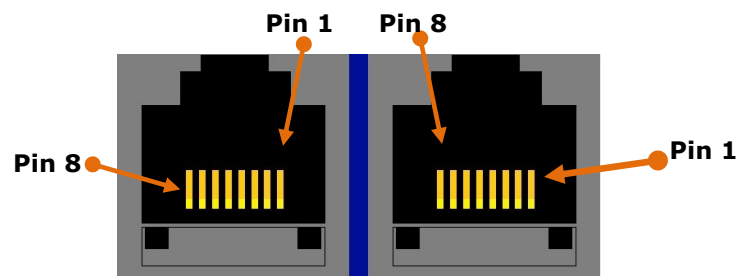

Figure 17 - RJ45 Ports Pin orientation

Pin Number	1	2	3,6	4,5	7,8
Function	RS485 B/Z	RS485 A/Y	Pins Connected	DC_IN/ OUT	GND

Table 10 - RJ45 Ports Pin Function

5.4.2 Powering and Communication

The RJ45 ports support both power and data transmission. Below are two methods for supplying power and communicating with the IDP-5000-04A module.

Method 1: Use of BRTSys LDS Bus USB Adaptor

For development purposes, developers can use a BRTSys **LDS Bus USB Adaptor** designed for RS485 device applications. Refer to the purchase link below for the adaptor and an illustration in Figure 18 and Figure 19.

- [BRTSys – LDS Bus USB Adaptor](#)

Figure 18 - BRTSys LDS Bus USB Adaptor

For connection details when using the adaptor, see Figure 19.

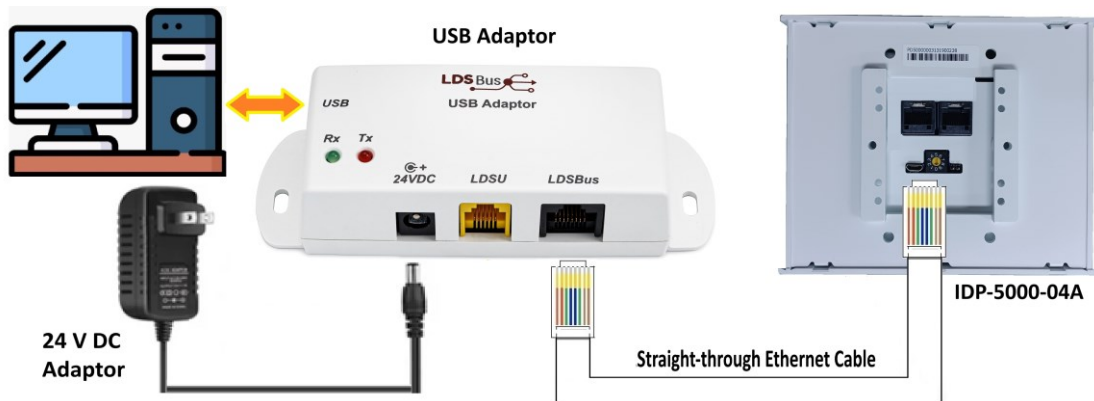
Figure 19 - Connection to PC and Supply via LDS Bus USB Adaptor

Method 2: Use of Power-over-Ethernet (PoE) Splitter

A **PoE splitter** can separate power and data, enabling connection to both a power source and a host controller. An illustration of the PoE splitter is provided in Figure 20 and Figure 21. The purchase links are:

- [PoE Splitter - Digikey](#)
- [PoE Splitter- AliExpress](#)

Figure 20 - PoE Splitter

Refer to Figure 21 for connection details using a PoE splitter.

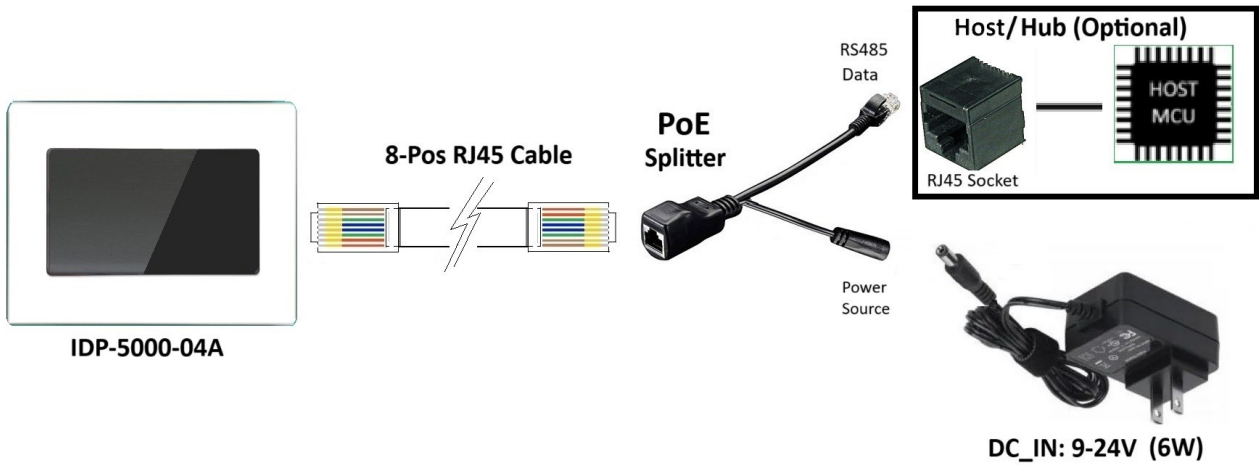

Figure 21 - Connection to Host and Supply via PoE Splitter

5.4.3 Port Connection

The RJ45 ports share identical connections, with their power lines shorted through a 0-ohm resistor and RS485 signals linked. When a power source or interface is connected to one port, it is automatically routed to the other. Refer to Figure 22 below for a simplified block diagram of the IDP-5000-04A's internal RJ45 connections.

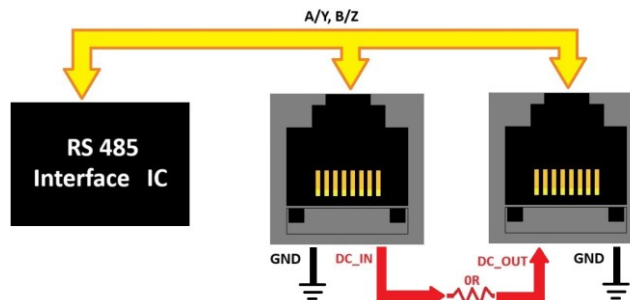

Figure 22 - PCB Connections of RJ45 Ports

Caution: Only one power source should be supplied at a time.

5.4.4 Port termination

The **IDP-5000-04A port terminator** contains a 120Ω resistor across the RS485 bus (pins 1 and 2 of the port). When using the IDP-5000-04A module as a standalone device or as the last unit in a Daisy Chain configuration, connect the port terminator to the final RJ45 port as illustrate in Figure 23.

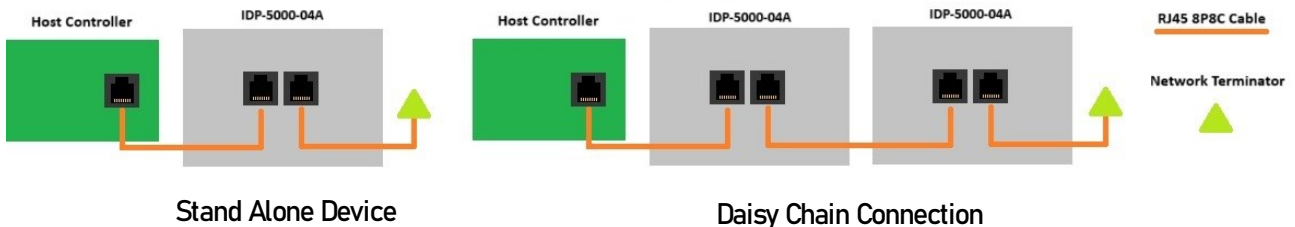

Figure 23 - Port Termination

5.5 LED Indicator

An integrated smart RGB LED provides programmable status indications. Located on the module's side (Figure 15), it processes a 24-bit color signal via clock and data inputs.

5.6 ID Switch

The ID switch on the module's back (Figure 16) allows custom configurations or use of the default factory setting (zero). It assists with device management in multi-device setups or boot mode configurations.

5.7 Reset Button

The module includes a reset button positioned on the side (Figure 15). The reset function can be activated by pressing through the designated hole.

5.8 Micro USB

A micro USB connector interfaces with the FT903 microcontroller, enabling communication and firmware downloads to the integrated NOR flash. Detailed setup instructions can be found in the section [8 Software Setup Information](#).

5.9 One Wire Debug

A one-wire debug function is accessible via the 2-position header on the module's back (Figure 16), connecting to the microcontroller. This mode allows code, firmware, and bootloader downloads to the NOR flash. Refer to section [8 Software Setup Information](#) for installation details.

5.10 Buzzer

The IDP-5000-04A display module includes an integrated buzzer circuit for event notifications.

5.11 Microphone

The IDP-5000-04A display module includes a built-in digital microphone for capturing audio signals. The microphone module and its acoustic opening are positioned on the side of the display module (see Figure 15).

Data input of the microphone is converted by Analog Devices [ADAU7002](#) Pulse Density Modulation (PDM) to I²S/TDM format for recording by MCU.

6 Specifications

6.1 Electrical Specifications

Parameter		Min	Typ	Max	Unit
DC_IN	Input voltage range	9	24.0	28	V
DC_OUT	Output voltage range	-	DC_IN	-	V
Icc_12V	Operating current, DC_IN=12V: Normal *Note	-	300	-	mA
V _{OD1}	Driver Differential VOUT (no load)	-	-	3.3	V
V _{OD2}	Driver Differential VOUT (with load)				
	RL=100Ω (RS-422) (Figure 24)	2	2.7	-	V
	RL = 54Ω (RS-485) (Figure 24)	1.5	2.3	3.3	
	RL = 60Ω, -7V ≤ VCM ≤ 12V	1.5	2.6	-	
ΔV _{OD}	Change in Magnitude of Driver Differential VOUT for Complementary Output States RL = 54Ω or 100Ω (Figure 24)	-	0.01	0.2	V
V _{OC}	Driver Common-Mode VOUT RL = 54Ω or 100Ω (Figure 24)	-	1.8	3	V
ΔV _{OC}	Change in Magnitude of Driver Common-Mode VOUT for Complementary Output States RL = 54Ω or 100Ω (Figure 24)	-	0.01	0.2	V
Temperature	Operating temperature	0	-	55	°C
	Storage temperature	0	-	70	

Table 11 - Operating Voltage and Current

Note: Measurement taken with the screen turned on.

Test Circuits

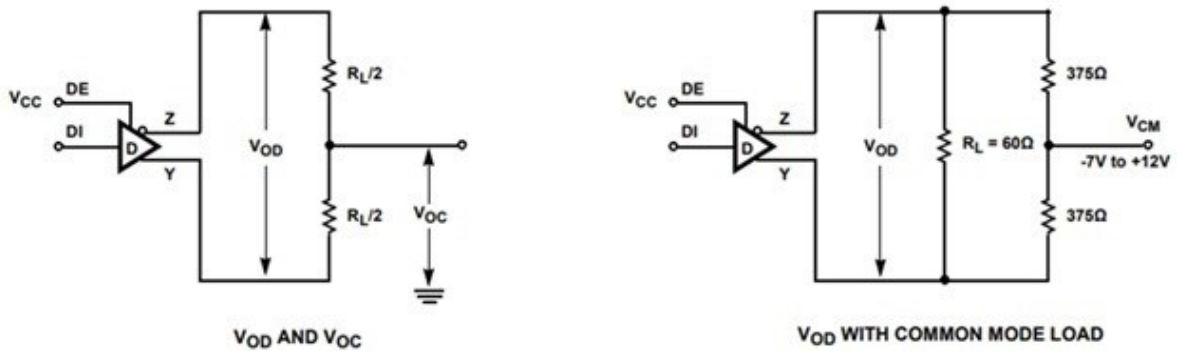

Figure 24 - DC Driver Test Circuits

6.2 Optical Specifications

Item	Symbol	Condition	Min.	Typ.	Max.	Unit	
Brightness	Bp	$\theta=0^\circ$ $\square=0^\circ$	-	420	-	Cd/m^2	
Uniformity	ΔBp		75	-	-	%	
Viewing Angle	3:00	$Cr \geq 10$	-	65	-	Deg	
	6:00		-	65	-		
	9:00		-	65	-		
	12:00		-	65	-		
Contrast Ratio	Cr	$\theta=0^\circ$ $\square=0^\circ$	300	500	-	-	
Response Time	$T_r + T_f$		-	10	-	ms	
Color of CIE Coordinate	W	x	$\theta=0^\circ$ $\square=0^\circ$	-	0.28	-	-
		y		-	0.33	-	-
	R	x		-	0.51	-	-
		y		-	0.34	-	-
	G	x		-	0.31	-	-
		y		-	0.56	-	-
	B	x		-	0.15	-	-
		y		-	0.14	-	-
NTSC Ratio	S		50	60	-	%	

Table 12 - Optical Specifications

Note: The parameter is slightly changed by temperature, driving voltage and material

7 Mechanical Dimensions and Mounting Guides

7.1 Dimensions

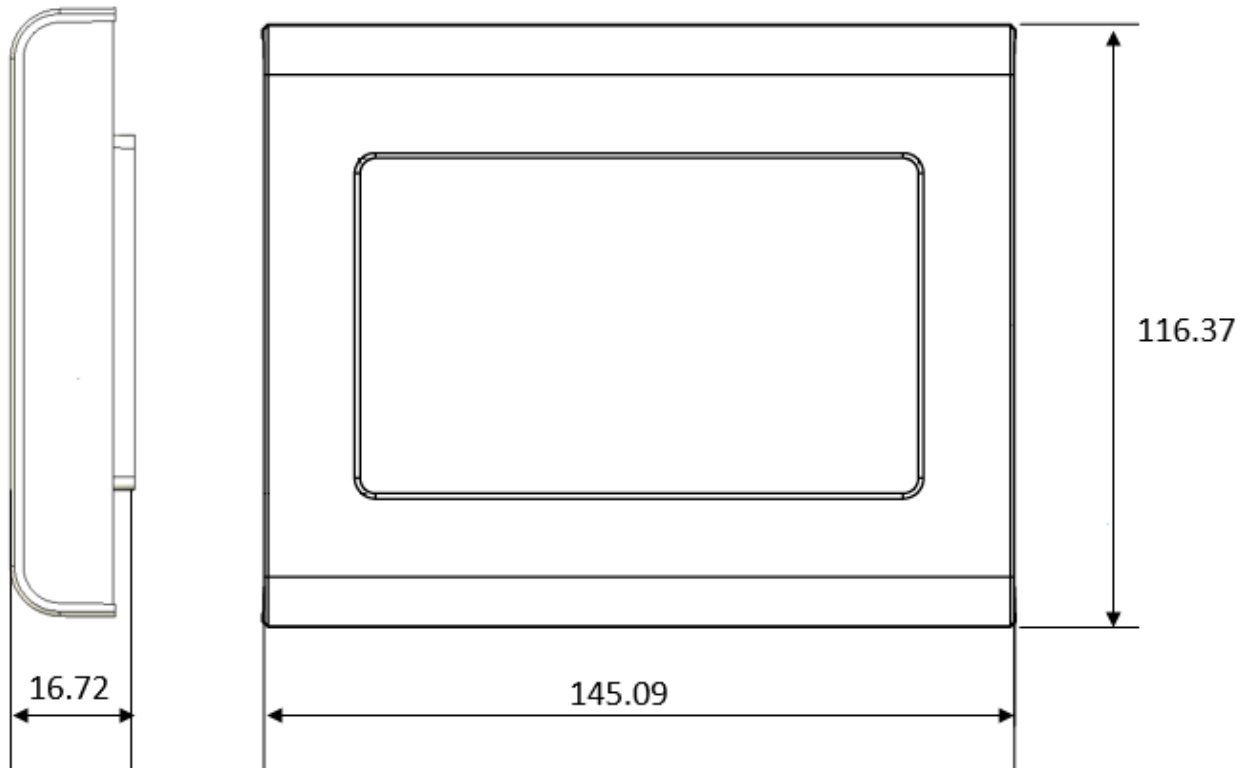

Figure 25 - IDP-5000-04A Touch Display Dimensions

7.2 Mounting Guides

The following steps provide guidance on wall mounting the IDP-5000-04A module.

1. Secure the IDP-5000-04A back cover using one of the following methods:
 - Attach it to an Arlington LV2* bracket with the provided self-tapping screws (3.5mm x 16mm, minimum length 12mm), refer to Figure 30.
 - Mount it onto a standard 86mm x 86mm x 40mm electrical junction box using screws (minimum length 12mm, maximum length 20mm, not included in package), refer to Figure 27.
2. Connect RJ45 8P8C cable and add a terminator, refer to Section [5](#).
3. Install the front panel on back cover and secure the panel.



Figure 26 - Arlington LV2 Mounting

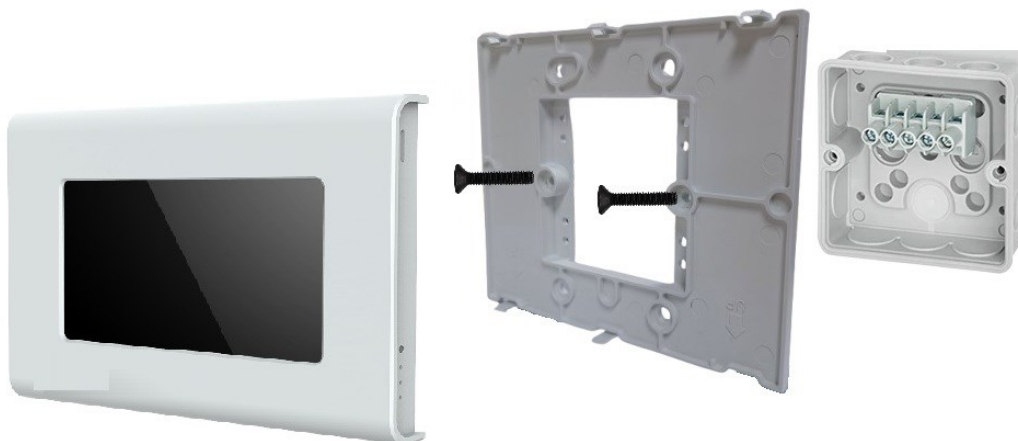

Figure 27 - Electrical Junction Box Mounting

**Arlington LV2 low voltage mounting bracket and electrical junction box are not part of the package. Electrical junction box screws not provided.*

8 Software Setup Information

8.1 Startup Test

The device comes preloaded with default firmware stored in the integrated NOR-Flash. Follow these steps to perform an initial test of the set before flashing developers' own code.

Step 1: Powering Up the Device

Connect the device to power source via the RJ45 connector. For details, refer to section [5.4.2 Powering and Communication](#).

Step 2: Touch Calibration

When powered on, the display module's preloaded firmware will prompt the user to perform a touch calibration test, as shown in Figure 28. During calibration process, an audible beep tone will be activated. Complete the calibration as required for the application.

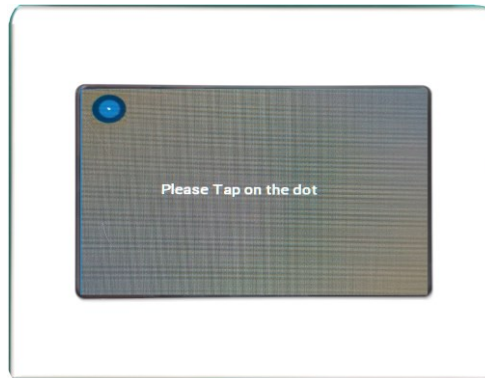

Figure 28 - Touch Calibration

Once the CTP is successfully calibrated, the Bridgetek company logo will be displayed as shown in Figure 29.



Figure 29 - Bridgetek Logo

Conducting this startup test ensures the device is operational before developers load their custom code.

8.2 Firmware Download and Debugging Methods for FT903 MCU

There are two methods for downloading firmware and debugging with the FT903 MCU:

Method 1: One Wire Communication Mode

This method requires additional hardware, specifically the UMFTPD2A programming module developed by Bridgetek, which supports downloading of firmware and debugging. For detailed information on the module and hardware pin definitions, refer to the [UMFTPD2A](#) link.

To establish the hardware connection, simply connect the **DBG** (CN2/CN3-8) and **GND** (CN2/CN3-7) pins from UMFTPD2A to the **One-Wire Debug** header pins of IDP-5000-04A display module, as shown in Figure 30.

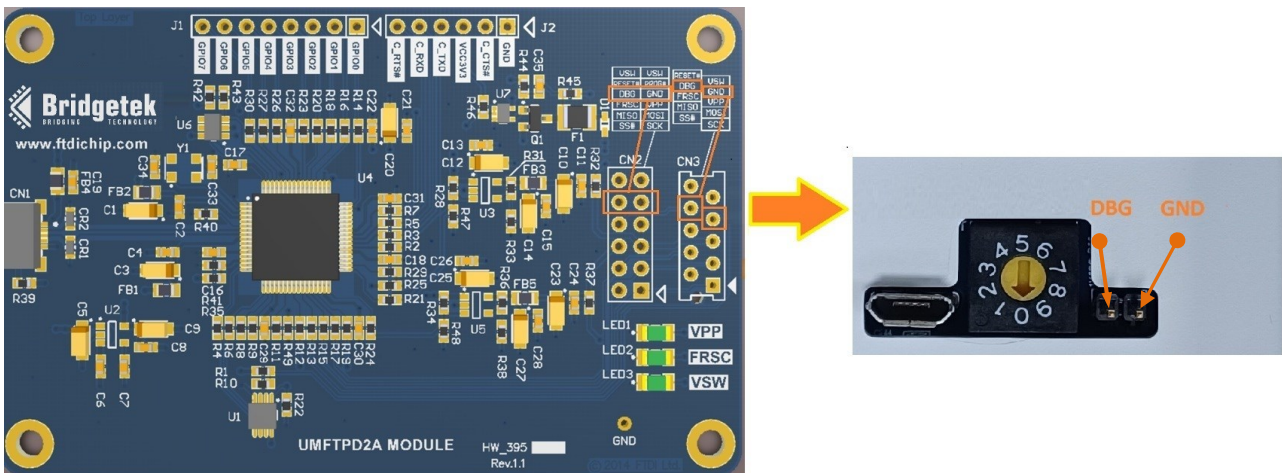

Figure 30 - One-Wire Debug Mode Hardware Connection

Method 2: USB Communication Mode

The USB-micro connector at the back of the module facilitates communication with the FT903 MCU. The application code can configure this USB port as either a **Device Firmware Upgrade (DFU)** port or a USB CDC serial port.



Figure 31 - USB Mode Communication

For more details, refer to the [FT9xx Programming-Debugging-and-Troubleshooting Guide](#).

8.3 Software Development Tools and Support

Bridgetek provides free and comprehensive software tools to simplify application development:

- **FT9XX Toolchain** - [Download here](#)
- **EVE Toolchain** - [Download here](#)

For example, projects, documentation, and additional support resources, please refer to the dedicated open-source repository:

<https://github.com/Bridgetek/IDP-5000-04A>

9 Disclaimer Notice: Use of Third-Party Software or Websites

We may recommend use of software or web sites that are owned or operated by other companies. We offer or facilitate this recommendation by hyperlinks or other methods to aid your access to the third-party resource. While we endeavour to direct you to helpful, trustworthy resources, we cannot endorse, approve, or guarantee software, information, products, or services provided by or at a third-party resource or track changes in the resource. Thus, we are not responsible for the content or accuracy of any third-party resource or for any loss or damage of any sort resulting from the use of, or for any failure of, products or services provided at or from a third party resource.

We recommend these resources on an "as is" basis. When you use a third party resource, you will be subject to its terms and licenses and no longer be protected by our privacy policy or security practices, which may differ from the third policy or practices or other terms. You should familiarize yourself with any license or use terms of, and the privacy policy and security practices of, the third party resource, which will govern your use of that resource.

10 Warranty Statement

According to our after-sales policy, the warranty (if applicable) will be void under the following circumstances:

- The device has been damaged due to human factors, such as dropping, impact, water exposure, or unauthorized disassembly/modification.
- The device has malfunctioned due to improper use, mishandling, or usage beyond its intended design.
- The device has been disassembled, repaired, or modified by unauthorized personnel.
- Any other conditions that do not comply with our warranty policy.

11 Contact Information

Refer to <https://brtchip.com/contact-us/> for contact information.

Distributor and Sales Representatives

Please visit the Distribution Network – IC & Module (brtchip.com) page for the contact details of our distributor sales representative(s) in your country.

System and equipment manufacturers and designers are responsible to ensure that their systems, and any Bridgetek Pte Ltd (BRTChip) devices incorporated in their systems, meet all applicable safety, regulatory and system-level performance requirements. All application-related information in this document (including application descriptions, suggested Bridgetek devices and other materials) is provided for reference only. While Bridgetek has taken care to assure it is accurate, this information is subject to customer confirmation, and Bridgetek disclaims all liability for system designs and for any applications assistance provided by Bridgetek. Use of Bridgetek devices in life support and/or safety applications is entirely at the user's risk, and the user agrees to defend, indemnify and hold harmless Bridgetek from any and all damages, claims, suits, or expense resulting from such use. This document is subject to change without notice. No freedom to use patents or other intellectual property rights is implied by the publication of this document. Neither the whole nor any part of the information contained in, or the product described in this document, may be adapted, or reproduced in any material or electronic form without the prior written consent of the copyright holder. Bridgetek Pte Ltd, 1 Tai Seng Avenue, Tower A, #03-05, Singapore 536464. Singapore Registered Company Number: 201542387H.

Appendix A - References

Document References

[DS_FT903](#)

[DS_FT81x](#)

Acronyms and Abbreviations

Terms	Description
CTP	Capacitive Touch Panel
DFU	Device Firmware Upgrade
EVE	Embedded Video Engine
I/O	Input/Output
IC	Integrated Circuit
LCD	Liquid Crystal Display
LED	Light Emitting Diode
MCU	Microcontroller Unit
MIC	Microphone
PCB	Printed Circuit Board
PCBA	Printed Circuit Board Assembly
RISC	Reduced Instruction Set Computer
RGB	Red, Green Blue
TFT	Thin Film Transistor
USB	Universal Serial Bus

Appendix B - List of Figures and Tables

List of Figures

Figure 1 - Front View of IDP-5000-04A Module	6
Figure 2 - Back View of IDP-5000-04A Module.....	6
Figure 3 - Mainboard PCBA Front View.....	7
Figure 4 - Mainboard PCBA Back View	7
Figure 5 - Sensor Board Front View.....	8
Figure 6 - Sensor Board Back View	8
Figure 7 - Main PCB Top Layer.....	9
Figure 8 - Main PCB Bottom Layer.....	9
Figure 9 - Sensor PCB Top Layer	9
Figure 10 - Sensor PCB Bottom Layer.....	9
Figure 11 - 5-inch TFT LCD Display	14
Figure 12 - I/O Accessories	15
Figure 13 - MCU Controller.....	16
Figure 14 - Sensor Board	17
Figure 15 - IDP-5000-04A Touch Display Front View	18
Figure 16 - IDP-5000-04A Touch Display Rear View	18
Figure 17 - RJ45 Ports Pin orientation.....	19
Figure 18 - BRTSys LDS Bus USB Adaptor.....	20
Figure 19 - Connection to PC and Supply via LDS Bus USB Adaptor.....	20
Figure 20 - PoE Splitter	20
Figure 21 - Connection to Host and Supply via PoE Splitter	21
Figure 22 - PCB Connections of RJ45 Ports.....	21
Figure 23 - Port Termination	21
Figure 24 - DC Driver Test Circuits.....	23
Figure 25 - IDP-5000-04A Touch Display Dimensions	25
Figure 26 - Arlington LV2 Mounting	26
Figure 27 - Electrical Junction Box Mounting	26
Figure 28 - Touch Calibration	27
Figure 29 - Bridgetek Logo.....	27
Figure 30 - One-Wire Debug Mode Hardware Connection	28
Figure 31 - USB Mode Communication	28

List of Tables

Table 1 - Part Number/Ordering Information	3
--	---

Table 2 - Package Content	3
Table 3 - CN1 Pinout	11
Table 4 - CN2 Pinout	11
Table 5 - CN3 Pinout	11
Table 6 - CN6 Pinout	12
Table 7 - CN8 Pinout	12
Table 8 - CN9 Pinout	13
Table 9 - CN100 Pinout.....	13
Table 10 - RJ45 Ports Pin Function	20
Table 11 - Operating Voltage and Current.....	23
Table 12 - Optical Specifications	24

Appendix C – Revision History

Document Title: IDP-5000-04A Touch Display Module Datasheet
Document Reference No.: BRT_000454
Clearance No.: BRT#222
Product Page: <https://brtchip.com/product/idp-5000-04a>
Document Feedback: [Send Feedback](#)

Revision	Changes	Date
Version 1.0	Initial Release	07-03-2025
Version 1.1	Updated the following – Product Name; Part Number/Ordering Information; Product page hyperlink; Github hyperlink Added Disclaimer & Warranty Statement section	07-04-2025