

# IDP-3510-04A Display Module Datasheet



## 1 Introduction

The IDP-3510-04A is a display module featuring a 3.5" TFT LCD panel with a resolution of 320x240. It integrates Bridgetek's proprietary Embedded Video Engine (EVE) Graphic Controller, the FT813, providing an intuitive interface for monitoring and triggering control events.

Powered by the ESP32-WROOM-32E microcontroller (MCU) with an onboard PCB antenna, the module supports Wi-Fi, Bluetooth®, and Bluetooth LE, enabling wireless connectivity for users. It also includes a built-in buzzer for event notifications and an RGB LED strip light indicator that can be programmed with different color codes to represent specific application events.

Designed for convenience, the display module can be placed on any flat surface. Power is supplied through a 5V Micro-USB adapter and cable, which are included with the module.

## 1.1 Features

- Driven by ESP32-WROOM-32E MCU module, featuring an Xtensa dual-core 32-bit LX6 microprocessor running at up to 240 MHz.
- Built-in advanced FT813 graphics controller with display, touch, and audio functionality
- 3.5" high brightness TFT LCD (320\*240 pixels)
- Supports Wi-Fi 802.11b/g/n (2.4GHz), up to 150Mbps
- Built-in Buzzer
- RGB LED Strip Indicator
- Micro USB Type B Port
- DC Power: 5V / 1A
- Sleek and modern design

Neither the whole nor any part of the information contained in, or the product described in this manual, may be adapted or reproduced in any material or electronic form without the prior written consent of the copyright holder. This product and its documentation are supplied on an as-is basis and no warranty as to their suitability for any particular purpose is either made or implied. Bridgetek Pte Ltd will not accept any claim for damages howsoever arising as a result of use or failure of this product. Your statutory rights are not affected. This product or any variant of it is not intended for use in any medical appliance, device or system in which the failure of the product might reasonably be expected to result in personal injury. This document provides preliminary information that may be subject to change without notice. No freedom to use patents or other intellectual property rights is implied by the publication of this document. Bridgetek Pte Ltd, 1 Tai Seng Avenue, Tower A, #03-05, Singapore 536464. Singapore Registered Company Number: 201542387H.

## 1.2 Typical Applications

- Home Automation Systems: Smart Thermostats, Lighting Control.
- Audio Equipment: Mixing Consoles, Hi-Fi Systems.
- Medical Devices: Portable Medical Monitors, Patient Monitoring Devices.
- Industrial Applications: Control Panels, Measurement Instrument.
- Automotive Interfaces: Infotainment Systems, Dashboards
- Consumer Electronics: Smart Speakers and Media Players, portable Gaming Consoles.
- Test and Measurement Equipment such as Oscilloscopes and Multimeters.
- ..... and many more.

## 2 Part Number/Ordering Information

<b>Part No.</b>	<b>Description</b>
IDP-3510-04A	Intelligent Display Product 3.5 inch with Enclosure

**Table 1 - Part Number/Ordering Information**

## **Contents**

<b>1</b>	<b>Introduction</b>	<b>1</b>
1.1	Features	1
1.2	Typical Applications	2
<b>2</b>	<b>Part Number/Ordering Information</b>	<b>3</b>
<b>3</b>	<b>Hardware Features</b>	<b>6</b>
3.1	PCBA Profile	7
3.1.1	Mainboard	7
3.1.2	RGB LED Strip Light Indicator Board	8
3.1.3	Key Features	8
3.2	PCB Profile	8
3.3	Connectors, Switches and Buttons	10
3.3.1	Mainboard Connector	10
3.3.2	RGB LED Strip Light Indicator Board Connector	12
3.3.3	Switches and Buttons	12
<b>4</b>	<b>Board Schematics</b>	<b>13</b>
<b>5</b>	<b>Device Description and configuration</b>	<b>15</b>
5.1	Micro USB	16
5.2	Microcontroller	16
5.3	Graphic Controller	16
5.4	USB to UART Serial Interface	16
5.5	Buzzer	16
5.6	Power Indicator	16
5.7	RGB LED Strip Light Indicator	16
5.8	Function Button	16
<b>6</b>	<b>Specifications</b>	<b>17</b>
6.1	Electrical Specifications	17
6.2	Optical Specifications	17
<b>7</b>	<b>Mechanical Dimensions</b>	<b>18</b>

---

<b>8</b>	<b>Package Contents and Disassembly Guide .....</b>	<b>19</b>
8.1	Package Content .....	19
8.2	Disassembly Guide .....	19
<b>9</b>	<b>Software Setup Information .....</b>	<b>22</b>
9.1	Startup Test .....	22
9.2	Downloading Firmware .....	22
9.3	Software Development Tools and Support.....	22
<b>10</b>	<b>Disclaimer Notice: Use of Third-Party Software or</b>	
	<b>Websites .....</b>	<b>23</b>
<b>11</b>	<b>Warranty Statement.....</b>	<b>24</b>
<b>12</b>	<b>Contact Information .....</b>	<b>25</b>
	<b>Appendix A – References.....</b>	<b>26</b>
	Document References .....	26
	Acronyms and Abbreviations .....	26
	<b>Appendix B – List of Tables &amp; Figures.....</b>	<b>27</b>
	List of Tables .....	27
	List of Figures .....	27
	<b>Appendix C – Revision History.....</b>	<b>28</b>

### 3 Hardware Features

The IDP-3510-04A display module features a 3.5-inch TFT LCD panel with a resolution of 320x240 pixels. It is housed in a sleek L-shaped black polycarbonate enclosure, providing durability and a modern design. The module's dimensions are 85mm (L) x 67.80mm (H) x 70.05mm (W).

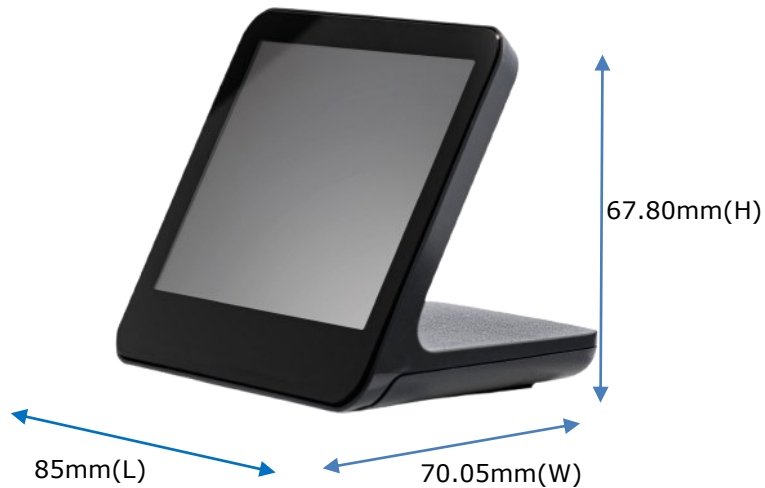

**Figure 1 - Dimension of IDP-3510-04A Module**



**Figure 2 - Front View of IDP-3510-04A Module**



**Figure 3 - Back View of IDP-3510-04A**

The IDP-3510-04A display module is made up of two separate boards:

1. **Mainboard:** PCBA containing an ESP32-WROOM-32E MCU module and FT813 graphics controller IC.
2. **RGB LED Strip Light Indicator Board:** PCBA containing RGB LED chips.

The following section provides the dimensions of these PCBAs.

### 3.1 PCBA Profile

#### 3.1.1 Mainboard

Dimensions of main board: 70mm (L) X 53.23mm (W) X 1mm (T) with tallest component height of approximately 3.7mm.

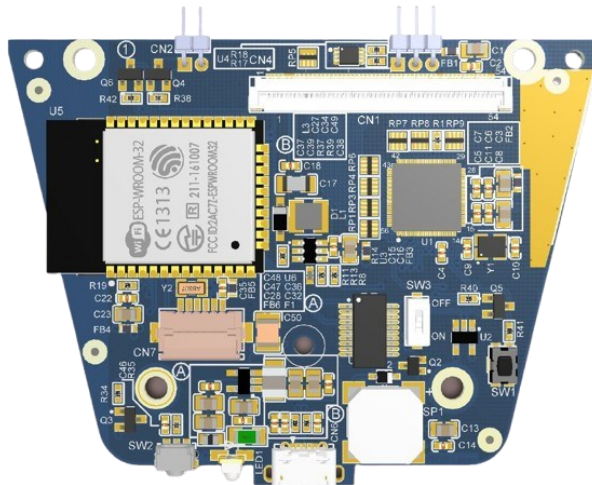

**Figure 4 - Mainboard PCBA-Front View**

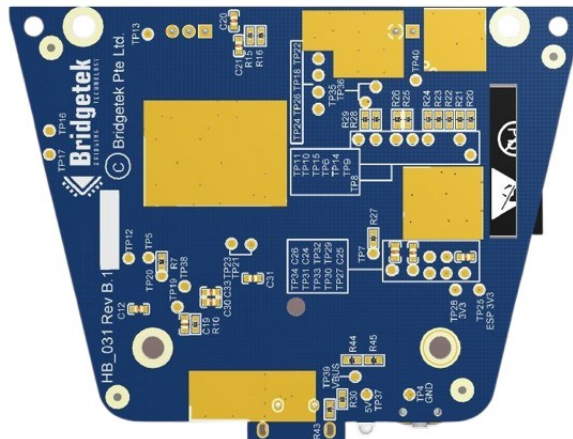

**Figure 5 - Mainboard PCBA-Back View**

### 3.1.2 RGB LED Strip Light Indicator Board

Dimensions of LED boards: 70mm (L) X 4.5mm (W) X 1mm (T) with tallest component height of approximately 0.9mm.



**Figure 6 - RGB LED Strip Light Indicator Board PCBA-Front View**



**Figure 7 - RGB LED Strip Light Indicator Board PCBA-Back View**

### 3.1.3 Key Features

- ❖ 3.5-inch 320 x 240 high brightness TFT LCD
- ❖ Bridgetek FT813 EVE chip for graphics, touch and audio controller
- ❖ ESP32-WROOM-32E microcontroller with an onboard antenna supporting Wi-Fi, Bluetooth, and Bluetooth LE
- ❖ Built-in FTDI FT231X USB-to-serial UART IC for connection to a PC or other USB hosts
- ❖ Micro-USB port for power supply and communication with the ESP32 MCU via the FT231X USB-to-serial UART IC
- ❖ 54-pin 0.5mm pitch FPC connector for LCD panel interconnection
- ❖ Built-in green colour LED indicator to indicate the power status (ON/OFF)
- ❖ Programmable RGB LED strip light indicator to assign color codes for specific application events
- ❖ Built-in audio buzzer for sound notifications
- ❖ A user-defined function button for accessing various settings, including display functions, brightness adjustment, volume control, and factory reset

**Note:** Default hardware configuration of the IDP-3510-04A does not support the touchscreen feature.

## 3.2 PCB Profile

All printed circuit boards (PCBs) in the IDP-3510-04A module is designed with four layers, stacked as follows:

1. Layer 1: Routing & Component placement (Top)
2. Layer 2: Ground Plane
3. Layer 3: Power Plane
4. Layer 4: Routing & Component placement (Bottom)

Figure 8 to Figure 11 provide the layout of these PCBs in the IDP-3510-04A module.



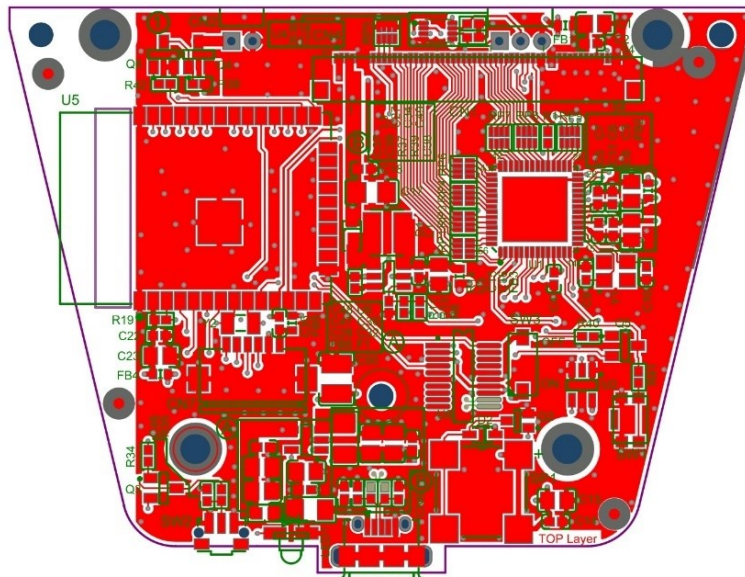

**Figure 8 - Main PCB Top Layer**

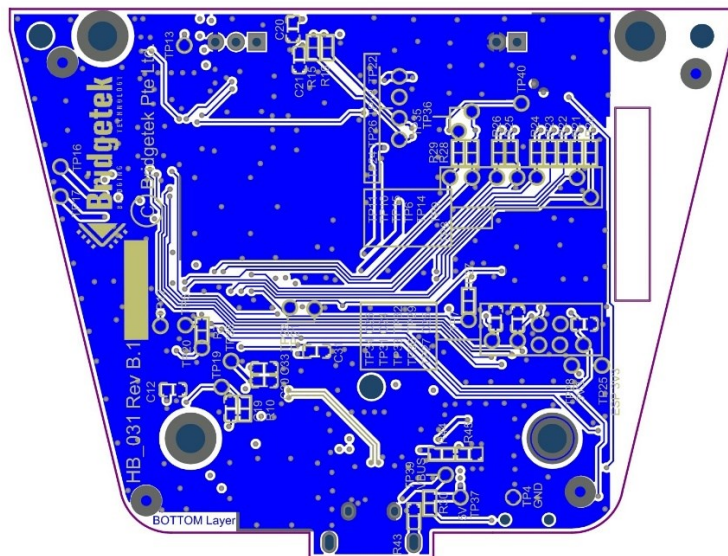

**Figure 9 - Main PCB Bottom Layer**



**Figure 10 - RGB LED Strip Light Indicator PCB Top Layer**



**Figure 11 - RGB LED Strip Light Indicator PCB Bottom Layer**

### 3.3 Connectors, Switches and Buttons

The following sections provide details about the connectors, their pin configurations, and the functions of the switches and buttons on the boards. Refer to Figure 4 for connector locations.

#### 3.3.1 Mainboard Connector

- **CN1 - LCD Panel Interface**

This 54-position, 0.5mm pitch bottom-contact FPC connector from Molex is used for inter-connection to the 3.5" LCD panel. The manufacturer's part number for this connector is "0512965494".

Pin No.	Name	Type	Description
1	LEDK	P	LED Cathode
2	LEDK	P	LED Cathode
3	LEDA	P	LED Anode
4	LEDA	P	LED Anode
5	GND	P	Ground
6	GND	P	Ground
7	GND	P	Ground
8	LCD_DISP	O	LCD display enable
9	-	-	33ohm resistor to GND
10	-	-	33ohm resistor to GND
11	-	-	33ohm resistor to GND
12	LCD_R0	O	Bit 0 of red channel in the RGB signal
13	LCD_R1	O	Bit 1 of red channel in the RGB signal
14	LCD_R2	O	Bit 2 of red channel in the RGB signal
15	LCD_R3	O	Bit 3 of red channel in the RGB signal
16	LCD_R4	O	Bit 4 of red channel in the RGB signal
17	LCD_R5	O	Bit 5 of red channel in the RGB signal
18	LCD_R6	O	Bit 6 of red channel in the RGB signal
19	LCD_R7	O	Bit 7 of red channel in the RGB signal
20	LCD_G0	O	Bit 0 of green channel in the RGB signal
21	LCD_G1	O	Bit 1 of green channel in the RGB signal
22	LCD_G2	O	Bit 2 of green channel in the RGB signal
23	LCD_G3	O	Bit 3 of green channel in the RGB signal
24	LCD_G4	O	Bit 4 of green channel in the RGB signal
25	LCD_G5	O	Bit 5 of green channel in the RGB signal
26	LCD_G6	O	Bit 6 of green channel in the RGB signal
27	LCD_G7	O	Bit 7 of green channel in the RGB signal
28	LCD_B0	O	Bit 0 of blue channel in the RGB signal
29	LCD_B1	O	Bit 1 of blue channel in the RGB signal
30	LCD_B2	O	Bit 2 of blue channel in the RGB signal
31	LCD_B3	O	Bit 3 of blue channel in the RGB signal
32	LCD_B4	O	Bit 4 of blue channel in the RGB signal
33	LCD_B5	O	Bit 5 of blue channel in the RGB signal
34	LCD_B6	O	Bit 6 of blue channel in the RGB signal

35	LCD_B7	O	Bit 7 of blue channel in the RGB signal
36	LCD_HC	O	LCD horizontal sync
37	LCD_VC	O	LCD vertical sync
38	LCD_PCLK	O	LCD pixel clock
39	GND	P	Ground
40	GND	P	Ground
41	LCD3V3	P	3.3V power supply
42	LCD3V3	P	3.3V power supply
43	GND	P	Ground
44	GND	P	Ground
45	GND	P	Ground
46	GND	P	Ground
47	GND	P	Ground
48	GND	P	Ground
49	GND	P	Ground
50	GND	P	Ground
51	GND	P	Ground
52	LCD_DE	O	LCD data enable
53	GND	P	Ground
54	GND	P	Ground

**Table 2 - CN1 Pinout**

- **CN2 – Power Supply Pin Header**

The 2-position, 2.54mm pitch pin header supplies 5V power to the RGB LED strip light indicator. This pin header is directly soldered to CN3 on the RGB LED strip light indicator board.

Pin No.	Name	Type	Description
1	LED_5V	P	5V power supply for RGB LED strip light indicator board, with ON/OFF control managed by the MCU
2	GND	P	Ground

**Table 3 - CN2 Pinout**

- **CN4 – Control Interface Pin Header**

The 3-position, 2.54mm pitch pin header is used to control the RGB LED strip light indicator, enabling users to assign color codes for specific application events. This pin header is directly soldered to CN5 on the RGB LED strip light indicator board.

Pin No.	Name	Type	Description
1	LED_K	I/O	Clock Line
2	LED_D	I/O	Data Line
3	GND	P	Ground

**Table 4 - CN4 Pinout**

- **CN6 – Micro-USB Receptacle**

The micro-USB receptacle provides power to the system and enables communication between the PC and the ESP32 MCU through the FT231X USB-to-serial UART interface IC.

### 3.3.2 RGB LED Strip Light Indicator Board Connector

- **CN3 – Power Supply Pin Header**

The 2-position, 2.54mm pitch pin header provides 5V power from the main board to the RGB LED strip light indicator. This pin header is directly soldered to CN2 on the main board.

Pin No.	Name	Type	Description
1	5V_LED	P	5V Input power supply
2	GND	P	Ground

**Table 5 - CN3 Pinout**

- **CN5 – Control Interface Pin Header**

The 3-position, 2.54mm pitch pin header is used to control the RGB LED strip light indicator, enabling users to assign color codes for specific application events. This pin header is directly soldered to CN4 on the main board.

Pin No.	Name	Type	Description
1	LED_CLOCK	I/O	Clock Line
2	LED_DATA	I/O	Data Line
3	GND	P	Ground

**Table 6 - CN5 Pinout**

### 3.3.3 Switches and Buttons

**SW1** is a reset button that allows the user to pull down the pin 3(EN) of the ESP32-WROOM-32E MCU module.

**SW2** is a function button that allows users to configure custom settings. It is connected to pin 25(IO0) of the ESP32-WROOM-32E MCU module.

**SW3** is a SPST slide switch used to enable or disable the power supply to the FT231X USB-to-serial UART interface IC. This switch must be turned on for programming and development purposes.

## 4 Board Schematics

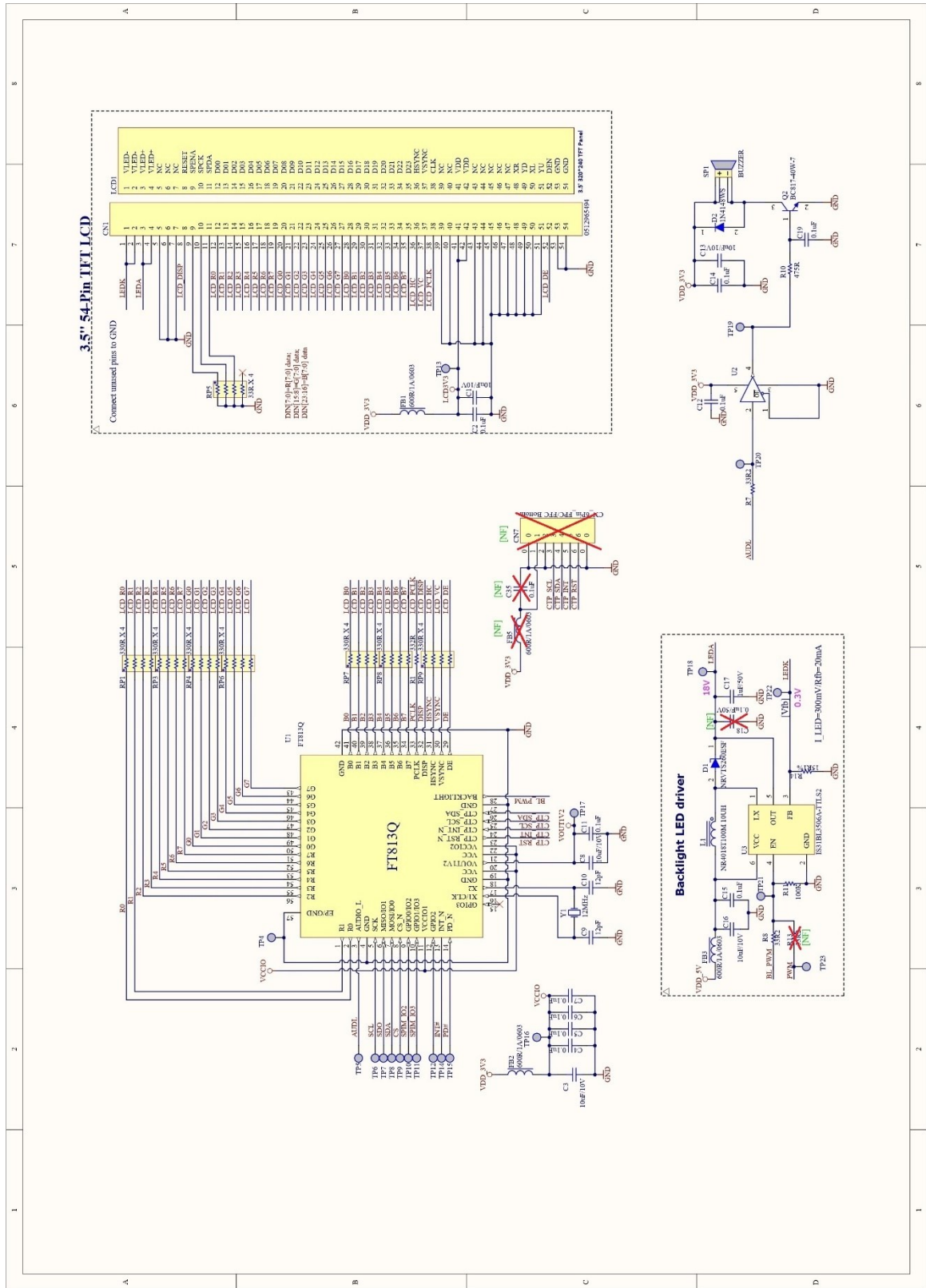

Figure 12 - FT813 EVE Graphic Controller

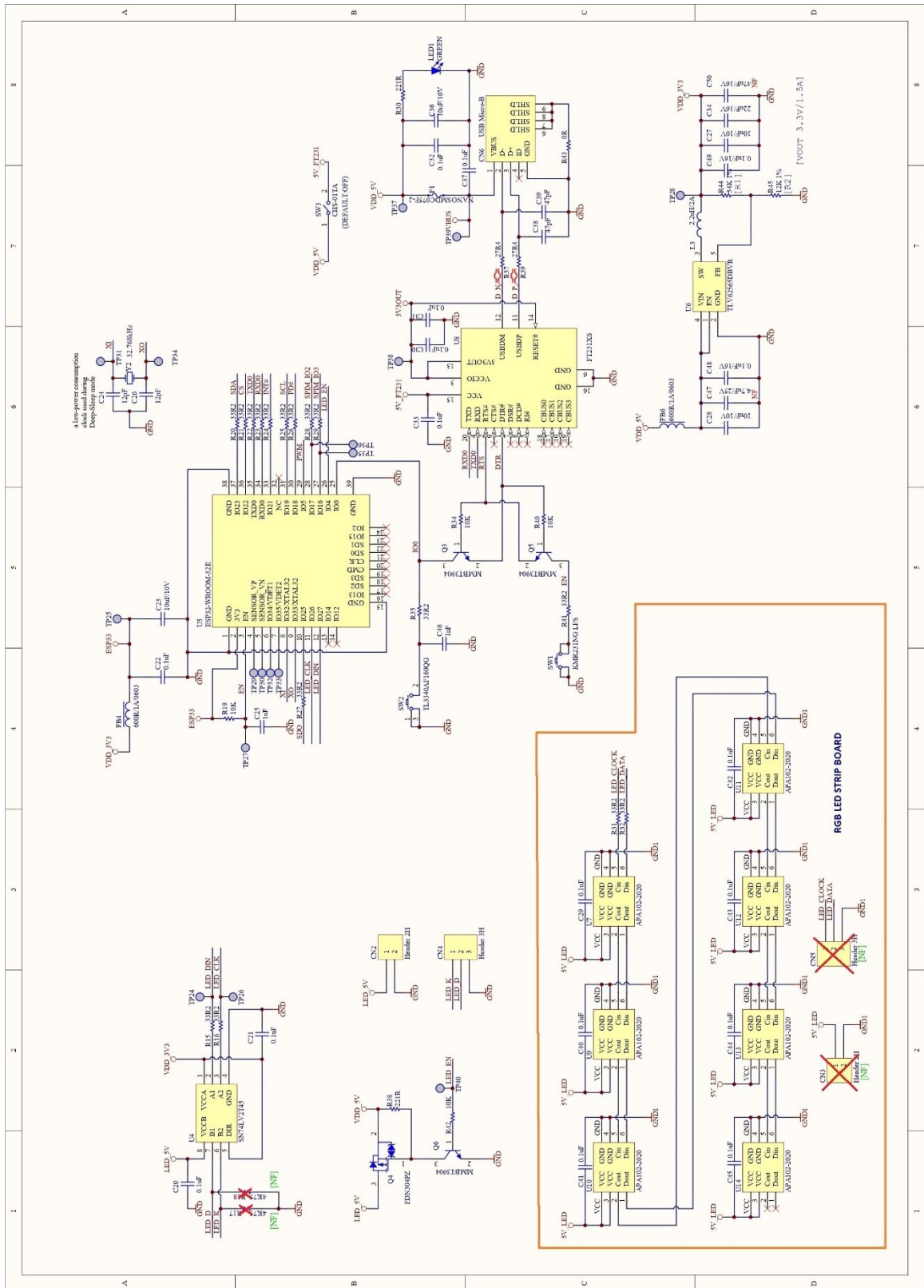

Figure 13 - ESP32 Microcontroller and RGB LED Strip Light Indicator Board

## 5 Device Description and configuration



**Figure 14 - IDP-3510-04A Display Front View**



**Figure 15 - IDP-3510-04A Display Rear View**

## 5.1 Micro USB

Power and data are supplied through the micro-USB receptacle located at the rear of the IDP-3510-04A display module. The module can be powered using a 5V/1A DC adapter. Additionally, it supports connection to a PC or host for communication with the ESP32 MCU via the onboard FT231X USB-to-serial UART interface IC.

## 5.2 Microcontroller

The ESP32-WROOM-32E is a powerful and versatile Wi-Fi, Bluetooth®, and Bluetooth LE MCU module with the following key features:

- Xtensa dual-core 32-bit LX6 microprocessor
- Supports Wi-Fi 802.11b/g/n (2.4GHz) with speeds up to 150Mbps
- Compatible with Bluetooth v4.2 BR/EDR and Bluetooth LE specifications
- Integrated with 16MB SPI flash

For full details of the ESP32-WROOM-32E MCU module, please refer to the [ESP32-WROOM-32E Datasheet](#).

## 5.3 Graphic Controller

The IDP-3510-04A utilizes Bridgetek's second-generation Advanced Embedded Video Engine (EVE) FT813, designed to deliver high-resolution graphics and video playback for creating high-quality Human Machine Interfaces (HMIs). It not only supports graphics but also features a touch screen interface and mono audio channel output with PWM output.

## 5.4 USB to UART Serial Interface

The FT231X is a USB-to-UART interface IC from FTDI that provides a simple way to add USB connectivity to embedded systems. It converts USB signals to standard asynchronous serial data (UART) and supports various baud rates.

## 5.5 Buzzer

The IDP-3510-04A display module includes an integrated buzzer circuit for event notifications.

## 5.6 Power Indicator

A green LED indicator, located at the back of the IDP-3510-04A display module, shows the power status (ON/OFF) of the module.

## 5.7 RGB LED Strip Light Indicator

The RGB LED strip light indicator consists of seven [APA102-202](#) Super LEDs, controlled by an MCU via a 2-wire communication protocol consisting of a clock and data line. This allows developers to customize the color codes and brightness of the LEDs to represent specific application events.

## 5.8 Function Button

The IDP-3510-04A display module features a built-in function button that allows users to configure custom settings for accessing various settings, such as brightness control, volume adjustment, or performing a factory reset. This button is located at the back of the display module, next to the power indicator LED, and can be activated by pressing through the designated hole.



## 6 Specifications

### 6.1 Electrical Specifications

Parameter		Min	Typ	Max	Unit
VDD_5V	Input voltage range	4.75	5.0	5.25	V
Icc_5V	Operating current, VDD_5V=5V: Normal <sup>*Note</sup>	-	450	-	mA
Temperature	Operating temperature	0	-	55	°C
	Storage temperature	0	-	70	

**Table 7 - Electrical Parameter**

**Note:** Measurement taken with the screen turned on.

### 6.2 Optical Specifications

Item	Symbol	Condition	Min.	Typ.	Max.	Unit
Brightness	Bp	$\theta=0^\circ$	-	500	-	Cd/m <sup>2</sup>
Uniformity	$\Delta Bp$	$\Phi=0^\circ$	80	-	-	%
Viewing Angle	3:00	$Cr \geq 10$	-	65	-	Deg
	6:00		-	55	-	
	9:00		-	65	-	
	12:00		-	65	-	
Contrast Ratio	Cr	$\theta=0^\circ$	300	500	-	-
Response Time	Tr	$\Phi=0^\circ$	-	10	-	ms
	Tf		-	10	-	ms
Color of CIE Coordinate	W	x	$\theta=0^\circ$ $\Phi=0^\circ$	0.30		-
		y		0.33		-
	R	x		0.63		-
		y		0.33		-
	G	x		0.28		-
		y		0.55		-
	B	x		0.14		-
		y		0.12		-
NTSC Ratio	S	-	60	-	%	

**Table 8 - Optical Specifications**

**Note:** The parameter is slightly changed by temperature, driving voltage and material

## 7 Mechanical Dimensions

Figure 16 illustrates the dimensions of IDP-3510-04A display module.

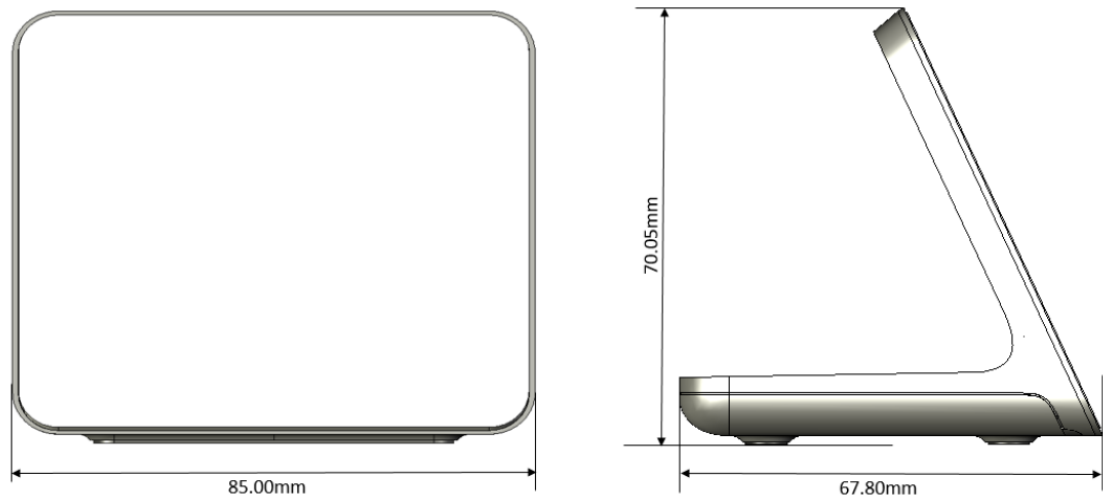

**Figure 16 - IDP-3510-04A Display Dimensions**

## 8 Package Contents and Disassembly Guide

The following section details the contents of the IDP-3510-04A package and provides a disassembly guide for accessing SW1 and SW3 to support the development.

### 8.1 Package Content

Table 9 below lists the contents included in the IDP-3510-04A package.

	Description	Quantity
<b>IDP-3510-04A Display Module</b>		
1	IDP-3510-04A Display Module	1
<b>Accessories</b>		
2	Region-specific 5V/1A DC Power Adapter	1
3	Micro-USB Cable (1.2m)	1
4	Double Sided Adhesive Tape for Rubber Foot	2

**Table 9 - Package Contents**

### 8.2 Disassembly Guide

This section outlines the disassembly process for the display module, allowing users to access SW1 and SW3 during development. Figure 17 illustrates the structure of IDP-3510-04A display module.

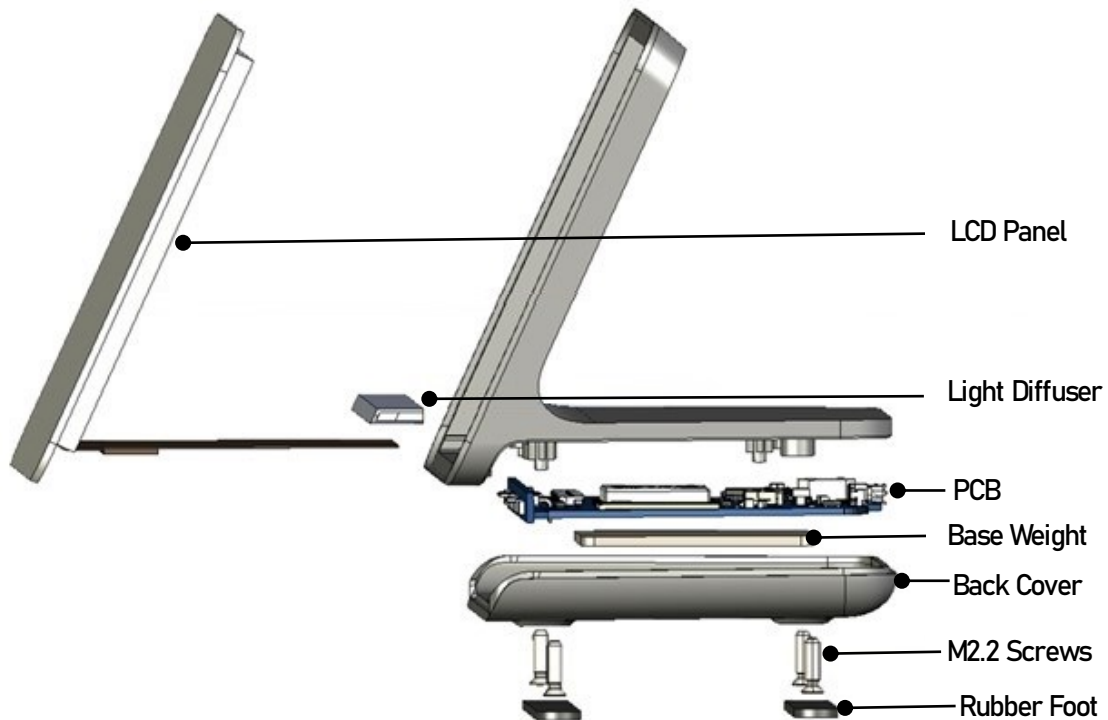

**Figure 17 - Structure of IDP-3510-04A Display Module**

The bottom cover can be easily removed by taking off the rubber foot and unscrewing four 2.2mm screws from the locations shown in Figure 18 and Figure 19.

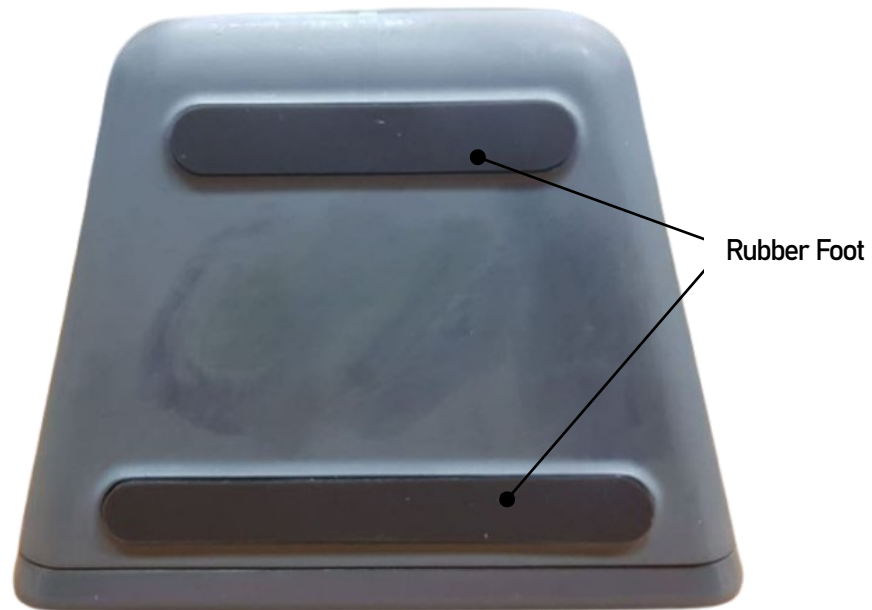

**Figure 18 - Remove Rubber Foot to Access the Screws**



**Figure 19 - Remove Screws To Detach Bottom Cover**

Once the bottom cover is removed, the main board becomes accessible. To reach SW1 and SW3, the user must flip the PCB to its top side.

Figure 20 shows the locations of SW1, SW2 and SW3.

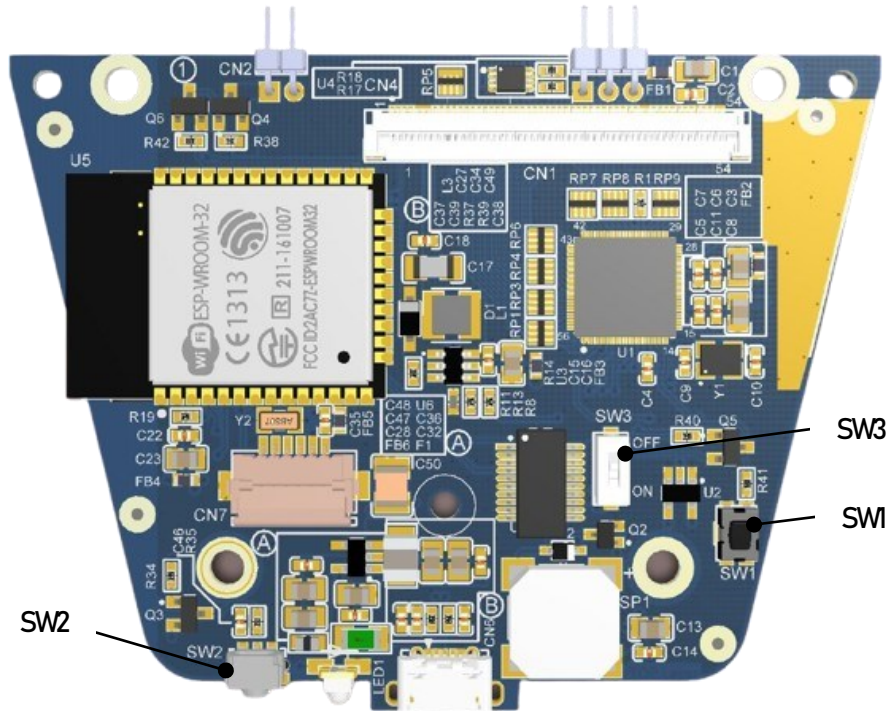

**Figure 20 - Locations of SW1, SW2 and SW3**

## 9 Software Setup Information

### 9.1 Startup Test

The device comes preloaded with default firmware stored in the flash memory of the ESP32-WROOM-32E MCU module. Upon powering the device via the micro-USB connector, the Bridgetek company logo will be displayed on the LCD screen and turning on the RGB LED strip light with a default blue color. Conducting this startup test ensures the device is operational before developers load their custom code.

### 9.2 Downloading Firmware

For firmware development, Bridgetek provides various development tools and sample codes to assist in the process. Refer to Section [9.3](#) for more details. The following section outlines the procedure for downloading the developer's firmware once it is ready.

Before downloading the firmware to the ESP32-WROOM-32E MCU module, ensure that SW3 is turned ON to enable the power supply to the FT231X USB-to-serial UART interface IC. The ESP32 MCU can be accessed via the micro-USB connector using the USB-to-UART interface.

There are two methods to enter boot mode of ESP32-WROOM-32E MCU, use one of the following methods:

#### **Method 1: Automatic Bootloader**

The ESP32 can be reset automatically by asserting DTR and RTS control lines of the FT231X USB to serial converter IC. These control lines are connected to the IO0 and EN pins of ESP32 module. Changes in the voltage levels of DTR and RTS will trigger the ESP32 to enter firmware download mode.

#### **Method 2: Manual Bootloader**

To manually enter boot mode:

1. Press and hold down SW2 (IO0) button
2. Press and release SW1 (EN) button while keeping SW2 (IO) held down
3. Release SW2 (IO) button after a second
4. ESP32 is now in boot mode and ready for flashing

### 9.3 Software Development Tools and Support

Bridgetek provides free, comprehensive software to help users develop applications with ease. For more information, please visit the following web portal:

<https://github.com/Bridgetek/>

## **10 Disclaimer Notice: Use of Third-Party Software or Websites**

We may recommend use of software or web sites that are owned or operated by other companies. We offer or facilitate this recommendation by hyperlinks or other methods to aid your access to the third-party resource. While we endeavour to direct you to helpful, trustworthy resources, we cannot endorse, approve, or guarantee software, information, products, or services provided by or at a third-party resource or track changes in the resource. Thus, we are not responsible for the content or accuracy of any third-party resource or for any loss or damage of any sort resulting from the use of, or for any failure of, products or services provided at or from a third party resource.

We recommend these resources on an "as is" basis. When you use a third party resource, you will be subject to its terms and licenses and no longer be protected by our privacy policy or security practices, which may differ from the third policy or practices or other terms. You should familiarize yourself with any license or use terms of, and the privacy policy and security practices of, the third party resource, which will govern your use of that resource.

## **11 Warranty Statement**

According to our after-sales policy, the warranty (if applicable) will be void under the following circumstances:

- The device has been damaged due to human factors, such as dropping, impact, water exposure, or unauthorized disassembly/modification.
- The device has malfunctioned due to improper use, mishandling, or usage beyond its intended design.
- The device has been disassembled, repaired, or modified by unauthorized personnel.
- Any other conditions that do not comply with our warranty policy.



## 12 Contact Information

Refer to <https://brtchip.com/contact-us/> for contact information.

### **Distributor and Sales Representatives**

Please visit the Distribution Network – IC & Module (brtchip.com) page for the contact details of our distributor(s) and sales representative(s) in your country.

System and equipment manufacturers and designers are responsible to ensure that their systems, and any Bridgetek Pte Ltd (BRTChip) devices incorporated in their systems, meet all applicable safety, regulatory and system-level performance requirements. All application-related information in this document (including application descriptions, suggested Bridgetek devices and other materials) is provided for reference only. While Bridgetek has taken care to assure it is accurate, this information is subject to customer confirmation, and Bridgetek disclaims all liability for system designs and for any applications assistance provided by Bridgetek. Use of Bridgetek devices in life support and/or safety applications is entirely at the user's risk, and the user agrees to defend, indemnify and hold harmless Bridgetek from any and all damages, claims, suits, or expense resulting from such use. This document is subject to change without notice. No freedom to use patents or other intellectual property rights is implied by the publication of this document. Neither the whole nor any part of the information contained in, or the product described in this document, may be adapted, or reproduced in any material or electronic form without the prior written consent of the copyright holder. Bridgetek Pte Ltd, 1 Tai Seng Avenue, Tower A, #03-05, Singapore 536464. Singapore Registered Company Number: 201542387H.

## Appendix A – References

### Document References

[FT813 Datasheet](#)

[ESP32-VROOM-32E Datasheet](#)

[FT231X Datasheet](#)

### Acronyms and Abbreviations

Terms	Description
DC	Direct Current
EVE	Embedded Video Engine
FPC	Flexible Printed Circuit
HMI	Human Machine Interfaces
IC	Integrated Circuit
LCD	Liquid Crystal Display
LED	Light Emitting Diode
LEDA	Light Emitting Diode Anode
LEDK	Light Emitting Diode Cathode
MCU	Micro Controller Unit
NTSC	National Television Standards Committee
PC	Personal Computer
PCB	Printed Circuit Board
PCBA	Printed Circuit Board Assembled
SPI	Serial Peripheral Interface
USB	Universal Serial Bus

## Appendix B – List of Tables & Figures

### List of Tables

Table 1 - Part Number/Ordering Information.....	3
Table 2 - CN1 Pinout.....	11
Table 3 - CN2 Pinout.....	11
Table 4 - CN4 Pinout.....	11
Table 5 - CN3 Pinout.....	12
Table 6 - CN5 Pinout.....	12
Table 7 - Electrical Parameter .....	17
Table 8 - Optical Specifications.....	17
Table 9 - Package Contents .....	19

### List of Figures

Figure 1 - Dimension of IDP-3510-04A Module.....	6
Figure 2 - Front View of IDP-3510-04A Module.....	6
Figure 3 - Back View of IDP-3510-04A .....	6
Figure 4 - Mainboard PCBA-Front View .....	7
Figure 5 - Mainboard PCBA-Back View.....	7
Figure 6 - RGB LED Strip Light Indicator Board PCBA-Front View .....	8
Figure 7 - RGB LED Strip Light Indicator Board PCBA-Back View.....	8
Figure 8 - Main PCB Top Layer .....	9
Figure 9 - Main PCB Bottom Layer .....	9
Figure 10 - RGB LED Strip Light Indicator PCB Top Layer.....	9
Figure 11 - RGB LED Strip Light Indicator PCB Bottom Layer.....	9
Figure 12 - FT813 EVE Graphic Controller .....	13
Figure 13 - ESP32 Microcontroller and RGB LED Strip Light Indicator Board .....	14
Figure 14 - IDP-3510-04A Display Front View .....	15
Figure 15 - IDP-3510-04A Display Rear View .....	15
Figure 16 - IDP-3510-04A Display Dimensions .....	18
Figure 17 - Structure of IDP-3510-04A Display Module.....	19
Figure 18 - Remove Rubber Foot to Access the Screws.....	20
Figure 19 - Remove Screws To Detach Bottom Cover.....	20
Figure 20 - Locations of SW1, SW2 and SW3 .....	21

## Appendix C – Revision History

Document Title: IDP-3510-04A Display Module Datasheet  
Document Reference No.: BRT\_000451  
**Clearance No.:** BRT#229  
Product Page: <https://brtchip.com/product/idp-3510-04a>  
Document Feedback: [Send Feedback](#)

Revision	Changes	Date
Version 1.0	Initial Release	07-04-2025